



## CONSOLE PROPOSAL SUBMITTAL PACKAGE



RESPONSE TO SOLICITATION: 24-21  
CONTROL ROOM CONSOLE SOLUTIONS

### SUBMITTED BY:

Adaptaspace Inc.  
6423-30<sup>th</sup> Street SE  
Calgary, Alberta T2C 1R4  
[www.adaptaspace.com](http://www.adaptaspace.com)

Marie McGinty  
VP Business Development  
E: [mmcginty@adaptaspace.com](mailto:mmcginty@adaptaspace.com)  
P: 403-203-2915 ext 220

# TAB 1 – MASTER AGREEMENT / SIGNATURE FORM



**RESPONSE TO REQUEST FOR PROPOSAL  
SUBMITTAL DATE – November 18, 2021**

**Response to Solicitation: 24-21  
Control Room Console Solutions**

# Tab 1 – Master Agreement General Terms and Conditions

---

- ◆ Customer Support
  - The vendor shall provide timely and accurate technical advice and sales support. The vendor shall respond to such requests within one (1) working day after receipt of the request.
  
- ◆ Disclosures
  - Respondent affirms that he/she has not given, offered to give, nor intends to give at any time hereafter any economic opportunity, future employment, gift, loan, gratuity, special discount, trip, favor or service to a public servant in connection with this contract.
  - The respondent affirms that, to the best of his/her knowledge, the offer has been arrived at independently, and is submitted without collusion with anyone to obtain information or gain any favoritism that would in any way limit competition or give an unfair advantage over other vendors in the award of this contract.
  
- ◆ Renewal of Contract
  - Unless otherwise stated, all contracts are for a period of three (3) years with an option to renew for up to two (2) additional one-year terms or any combination of time equally not more than 2 years if agreed to by Region 14 ESC and the vendor.
  
- ◆ Funding Out Clause
  - Any/all contracts exceeding one (1) year shall include a standard “funding out” clause. A contract for the acquisition, including lease, of real or personal property is a commitment of the entity’s current revenue only, provided the contract contains either or both of the following provisions:
    - Retains to the entity the continuing right to terminate the contract at the expiration of each budget period during the term of the contract and is conditioned on a best efforts attempt by the entity to obtain appropriate funds for payment of the contract.
  
- ◆ Shipments (if applicable)
  - The awarded vendor shall ship ordered products within seven (7) working days for goods available and within four (4) to six (6) weeks for specialty items after the receipt of the order unless modified. If a product cannot be shipped within that time, the awarded vendor shall notify the entity placing the order as to why the product has not shipped and shall provide an estimated shipping date. At this point the participating entity may cancel the order if estimated shipping time is not acceptable.
  
- ◆ Tax Exempt Status
  - Since this is a national contract, knowing the tax laws in each state is the sole responsibility of the vendor.

- ◆ Payments
  - The entity using the contract will make payments directly to the awarded vendor or their affiliates (distributors/business partners/resellers) as long as written request and approval by NCPA is provided to the awarded vendor.
- ◆ Adding authorized distributors/dealers
  - Awarded vendors may submit a list of distributors/partners/resellers to sell under their contract throughout the life of the contract. Vendor must receive written approval from NCPA before such distributors/partners/resellers considered authorized.
  - Purchase orders and payment can only be made to awarded vendor or distributors/business partners/resellers previously approved by NCPA.
  - Pricing provided to members by added distributors or dealers must also be less than or equal to the pricing offered by the awarded contract holder.
  - All distributors/partners/resellers are required to abide by the Terms and Conditions of the vendor's agreement with NCPA.
- ◆ Pricing
  - All pricing submitted shall include the administrative fee to be remitted to NCPA by the awarded vendor. It is the awarded vendor's responsibility to keep all pricing up to date and on file with NCPA.
  - All deliveries shall be freight prepaid, F.O.B. destination and shall be included in all pricing offered unless otherwise clearly stated in writing
- ◆ Warranty
  - Proposals should address each of the following:
    - Applicable warranty and/or guarantees of equipment and installations including any conditions and response time for repair and/or replacement of any components during the warranty period.
    - Availability of replacement parts
    - Life expectancy of equipment under normal use
    - Detailed information as to proposed return policy on all equipment
- ◆ Indemnity
  - The awarded vendor shall protect, indemnify, and hold harmless Region 14 ESC and its participants, administrators, employees and agents against all claims, damages, losses and expenses arising out of or resulting from the actions of the vendor, vendor employees or vendor subcontractors in the preparation of the solicitation and the later execution of the contract.
- ◆ Franchise Tax
  - The respondent hereby certifies that he/she is not currently delinquent in the payment of any franchise taxes.

◆ Supplemental Agreements

- The entity participating in this contract and awarded vendor may enter into a separate supplemental agreement to further define the level of service requirements over and above the minimum defined in this contract i.e. invoice requirements, ordering requirements, specialized delivery, etc. Any supplemental agreement developed as a result of this contract is exclusively between the participating entity and awarded vendor.

◆ Certificates of Insurance

- Certificates of insurance shall be delivered to the Public Agency prior to commencement of work. The insurance company shall be licensed in the applicable state in which work is being conducted. The awarded vendor shall give the participating entity a minimum of ten (10) days notice prior to any modifications or cancellation of policies. The awarded vendor shall require all subcontractors performing any work to maintain coverage as specified.

◆ Legal Obligations

- It is the Respondent's responsibility to be aware of and comply with all local, state, and federal laws governing the sale of products/services identified in this RFP and any awarded contract and shall comply with all while fulfilling the RFP. Applicable laws and regulation must be followed even if not specifically identified herein.

◆ Protest

- A protest of an award or proposed award must be filed in writing within ten (10) days from the date of the official award notification and must be received by 5:00 pm CST. Protests shall be filed with Region 14 ESC and shall include the following:
  - Name, address and telephone number of protester
  - Original signature of protester or its representative
  - Identification of the solicitation by RFP number
  - Detailed statement of legal and factual grounds including copies of relevant documents and the form of relief requested
- Any protest review and action shall be considered final with no further formalities being considered.

◆ Force Majeure

- If by reason of Force Majeure, either party hereto shall be rendered unable wholly or in part to carry out its obligations under this Agreement then such party shall give notice and full particulars of Force Majeure in writing to the other party within a reasonable time after occurrence of the event or cause relied upon, and the obligation of the party giving such notice, so far as it is affected by such Force Majeure, shall be suspended during the continuance of the inability then claimed, except as hereinafter provided, but for no longer period, and such party shall endeavor to remove or overcome such inability with all reasonable dispatch.
- The term Force Majeure as employed herein, shall mean acts of God, strikes, lockouts, or other industrial disturbances, act of public enemy, orders of any kind of government of the

United States or any civil or military authority; insurrections; riots; epidemics; landslides; lighting; earthquake; fires; hurricanes; storms; floods; washouts; droughts; arrests; restraint of government and people; civil disturbances; explosions, breakage or accidents to machinery, pipelines or canals, or other causes not reasonably within the control of the party claiming such inability. It is understood and agreed that the settlement of strikes and lockouts shall be entirely within the discretion of the party having the difficulty, and that the above requirement that any Force Majeure shall be remedied with all reasonable dispatch shall not require the settlement of strikes and lockouts by acceding to the demands of the opposing party or parties when such settlement is unfavorable in the judgment of the party having the difficulty

◆ Prevailing Wage

- It shall be the responsibility of the Vendor to comply, when applicable, with the prevailing wage legislation in effect in the jurisdiction of the purchaser. It shall further be the responsibility of the Vendor to monitor the prevailing wage rates as established by the appropriate department of labor for any increase in rates during the term of this contract and adjust wage rates accordingly.

◆ Miscellaneous

- Either party may cancel this contract in whole or in part by providing written notice. The cancellation will take effect 30 business days after the other party receives the notice of cancellation. After the 30th business day all work will cease following completion of final purchase order.

◆ Open Records Policy

- Because Region 14 ESC is a governmental entity responses submitted are subject to release as public information after contracts are executed. If a vendor believes that its response, or parts of its response, may be exempted from disclosure, the vendor must specify page-by-page and line-by-line the parts of the response, which it believes, are exempt. In addition, the respondent must specify which exception(s) are applicable and provide detailed reasons to substantiate the exception(s).
- The determination of whether information is confidential and not subject to disclosure is the duty of the Office of Attorney General (OAG). Region 14 ESC must provide the OAG sufficient information to render an opinion and therefore, vague and general claims to confidentiality by the respondent are not acceptable. Region 14 ESC must comply with the opinions of the OAG. Region 14 ESC assumes no responsibility for asserting legal arguments on behalf of any vendor. Respondent are advised to consult with their legal counsel concerning disclosure issues resulting from this procurement process and to take precautions to safeguard trade secrets and other proprietary information.

# Process

---

Region 14 ESC will evaluate proposals in accordance with, and subject to, the relevant statutes, ordinances, rules, and regulations that govern its procurement practices. NCPA will assist Region 14 ESC in evaluating proposals. Award(s) will be made to the prospective vendor whose response is determined to be the most advantageous to Region 14 ESC, NCPA, and its participating agencies. To qualify for evaluation, response must have been submitted on time, and satisfy all mandatory requirements identified in this document.

- ◆ Contract Administration
  - The contract will be administered by Region 14 ESC. The National Program will be administered by NCPA on behalf of Region 14 ESC.
- ◆ Contract Term
  - The contract term will be for three (3) year starting from the date of the award. The contract may be renewed for up to two (2) additional one-year terms or any combination of time equally not more than 2 years.
  - It should be noted that maintenance/service agreements may be issued for up to (5) years under this contract even if the contract only lasts for the initial term of the contract. NCPA will monitor any maintenance agreements for the term of the agreement provided they are signed prior to the termination or expiration of this contract.
- ◆ Contract Waiver
  - Any waiver of any provision of this contract shall be in writing and shall be signed by the duly authorized agent of Region 14 ESC. The waiver by either party of any term or condition of this contract shall not be deemed to constitute waiver thereof nor a waiver of any further or additional right that such party may hold under this contract.
- ◆ Products and Services additions
  - Products and Services may be added to the resulting contract during the term of the contract by written amendment, to the extent that those products and services are within the scope of this RFP.
- ◆ Competitive Range
  - It may be necessary for Region 14 ESC to establish a competitive range. Responses not in the competitive range are unacceptable and do not receive further award consideration.
- ◆ Deviations and Exceptions
  - Deviations or exceptions stipulated in response may result in disqualification. It is the intent of Region 14 ESC to award a vendor's complete line of products and/or services, when possible.
- ◆ Estimated Quantities
  - The estimated dollar volume of Products and Services purchased under the proposed Master Agreement is \$20 million dollars annually. This estimate is based on the anticipated volume of Region 14 ESC and current sales within the NCPA program. There is no guarantee or commitment of any kind regarding usage of any contracts resulting from this solicitation

- ◆ Evaluation
  - Region 14 ESC will review and evaluate all responses in accordance with, and subject to, the relevant statutes, ordinances, rules and regulations that govern its procurement practices. NCPA will assist the lead agency in evaluating proposals. Recommendations for contract awards will be based on multiple factors, each factor being assigned a point value based on its importance.
- ◆ Formation of Contract
  - A response to this solicitation is an offer to contract with Region 14 ESC based upon the terms, conditions, scope of work, and specifications contained in this request. A solicitation does not become a contract until it is accepted by Region 14 ESC. The prospective vendor must submit a signed Signature Form with the response thus, eliminating the need for a formal signing process.
- ◆ NCPA Administrative Agreement
  - The vendor will be required to enter and execute the National Cooperative Purchasing Alliance Administration Agreement with NCPA upon award with Region 14 ESC. The agreement establishes the requirements of the vendor with respect to a nationwide contract effort.
- ◆ Clarifications / Discussions
  - Region 14 ESC may request additional information or clarification from any of the respondents after review of the proposals received for the sole purpose of elimination minor irregularities, informalities, or apparent clerical mistakes in the proposal. Clarification does not give respondent an opportunity to revise or modify its proposal, except to the extent that correction of apparent clerical mistakes results in a revision. After the initial receipt of proposals, Region 14 ESC reserves the right to conduct discussions with those respondent's whose proposals are determined to be reasonably susceptible of being selected for award. Discussions occur when oral or written communications between Region 14 ESC and respondent's are conducted for the purpose clarifications involving information essential for determining the acceptability of a proposal or that provides respondent an opportunity to revise or modify its proposal. Region 14 ESC will not assist respondent bring its proposal up to the level of other proposals through discussions. Region 14 ESC will not indicate to respondent a cost or price that it must meet to neither obtain further consideration nor will it provide any information about other respondents' proposals or prices.
- ◆ Multiple Awards
  - Multiple Contracts may be awarded as a result of the solicitation. Multiple Awards will ensure that any ensuing contracts fulfill current and future requirements of the diverse and large number of participating public agencies.
- ◆ Past Performance
  - Past performance is relevant information regarding a vendor's actions under previously awarded contracts; including the administrative aspects of performance; the vendor's history of reasonable and cooperative behavior and commitment to customer satisfaction; and generally, the vendor's businesslike concern for the interests of the customer.



# Evaluation Criteria

---

- ◆ Pricing (40 points)
  - Electronic Price Lists
    - Products, Services, Warranties, etc. price list
    - Prices listed will be used to establish both the extent of a vendor's product lines, services, warranties, etc. available from a particular bidder and the pricing per item.
  
- ◆ Ability to Provide and Perform the Required Services for the Contract (25 points)
  - Product Delivery within participating entities specified parameters
  - Number of line items delivered complete within the normal delivery time as a percentage of line items ordered.
  - Vendor's ability to perform towards above requirements and desired specifications.
  - Past Cooperative Program Performance
  - Quantity of line items available that are commonly purchased by the entity.
  - Quality of line items available compared to normal participating entity standards.
  - Provide both On-premise solutions as well as Cloud based solutions.
  
- ◆ References (15 points)
  - A minimum of ten (10) customer references for product and/or services of similar scope dating within past 3 years
  
- ◆ Technology for Supporting the Program (10 points)
  - Electronic on-line catalog, order entry use by and suitability for the entity's needs
  - Quality of vendor's on-line resources for NCPA members.
  - Specifications and features offered by respondent's products and/or services
  
- ◆ Value Added Services Description, Products and/or Services (10 points)
  - Marketing and Training
  - Minority and Women Business Enterprise (MWBE) and (HUB) Participation
  - Customer Service

# Signature Form

---

The undersigned hereby proposes and agrees to furnish goods and/or services in strict compliance with the terms, specifications and conditions at the prices proposed within response unless noted in writing. The undersigned further certifies that he/she is an officer of the company and has authority to negotiate and bind the company named below and has not prepared this bid in collusion with any other Respondent and that the contents of this proposal as to prices, terms or conditions of said bid have not been communicated by the undersigned nor by any employee or agent to any person engaged in this type of business prior to the official opening of this proposal.

Prices are guaranteed: **120 days**

Company name	Adaptaspace Inc.
Address	6423-30th Street SE
City/State/Zip	Calgary, Alberta T2C 1R4
Telephone No.	403-203-2915 ext 290
Fax No.	403-203-0142
Email address	crenkas@adaptaspace.com
Printed name	Cameron Renkas
Position with company	President
Authorized signature	

## TAB 2 – NCPA ADMINISTRATION AGREEMENT



**RESPONSE TO REQUEST FOR PROPOSAL  
SUBMITTAL DATE – November 18, 2021**

**Response to Solicitation: 24-21  
Control Room Console Solutions**

# Tab 2 – NCPA Administration Agreement

---

This Administration Agreement is made as of December 13, 2021, by and between National Cooperative Purchasing Alliance (“NCPA”) and Adaptaspace Inc. (“Vendor”).

## Recitals

WHEREAS, Region 14 ESC has entered into a certain Master Agreement dated December 13, 2021, referenced as Contract Number 07-61, by and between Region 14 ESC and Vendor, as may be amended from time to time in accordance with the terms thereof (the “Master Agreement”), for the purchase of Control Room Console Solutions;

WHEREAS, said Master Agreement provides that any state, city, special district, local government, school district, private K-12 school, technical or vocational school, higher education institution, other government agency or nonprofit organization (hereinafter referred to as “public agency” or collectively, “public agencies”) may purchase products and services at the prices indicated in the Master Agreement;

WHEREAS, NCPA has the administrative and legal capacity to administer purchases under the Master Agreement to public agencies;

WHEREAS, NCPA serves as the administrative agent for Region 14 ESC in connection with other master agreements offered by NCPA

WHEREAS, Region 14 ESC desires NCPA to proceed with administration of the Master Agreement;

WHEREAS, NCPA and Vendor desire to enter into this Agreement to make available the Master Agreement to public agencies on a national basis;

NOW, THEREFORE, in consideration of the payments to be made hereunder and the mutual covenants contained in this Agreement, NCPA and Vendor hereby agree as follows:

### ◆ General Terms and Conditions

- The Master Agreement, attached hereto as Tab 1 and incorporated herein by reference as though fully set forth herein, and the terms and conditions contained therein shall apply to this Agreement except as expressly changed or modified by this Agreement.
- NCPA shall be afforded all of the rights, privileges and indemnifications afforded to Region 14 ESC under the Master Agreement, and such rights, privileges and indemnifications shall accrue and apply with equal effect to NCPA under this Agreement including, but not limited to, the Vendor’s obligation to provide appropriate insurance and certain indemnifications to Region 14 ESC.
- Vendor shall perform all duties, responsibilities and obligations required under the Master Agreement in the time and manner specified by the Master Agreement.
- NCPA shall perform all of its duties, responsibilities, and obligations as administrator of purchases under the Master Agreement as set forth herein, and Vendor acknowledges that NCPA shall act in the capacity of administrator of purchases under the Master Agreement.
- With respect to any purchases made by Region 14 ESC or any Public Agency pursuant to the Master Agreement, NCPA (a) shall not be construed as a dealer, re-marketer, representative, partner, or agent of any type of Vendor, Region 14 ESC, or such Public Agency, (b) shall not be obligated, liable or responsible (i) for any orders made by Region

14 ESC, any Public Agency or any employee of Region 14 ESC or Public Agency under the Master Agreement, or (ii) for any payments required to be made with respect to such order, and (c) shall not be obligated, liable or responsible for any failure by the Public Agency to (i) comply with procedures or requirements of applicable law, or (ii) obtain the due authorization and approval necessary to purchase under the Master Agreement. NCPA makes no representations or guaranties with respect to any minimum purchases required to be made by Region 14 ESC, any Public Agency, or any employee of Region 14 ESC or Public Agency under this Agreement or the Master Agreement.

- The Public Agency participating in the NCPA contract and Vendor may enter into a separate supplemental agreement to further define the level of service requirements over and above the minimum defined in this contract i.e. invoice requirements, ordering requirements, specialized delivery, etc. Any supplemental agreement developed as a result of this contract is exclusively between the Public Agency and Vendor. NCPA, its agents, members and employees shall not be made party to any claim for breach of such agreement.

◆ **Term of Agreement**

- This Agreement shall be in effect so long as the Master Agreement remains in effect, provided, however, that the obligation to pay all amounts owed by Vendor to NCPA through the termination of this Agreement and all indemnifications afforded by Vendor to NCPA shall survive the term of this Agreement.

◆ **Fees and Reporting**

- The awarded vendor shall electronically provide NCPA with a detailed quarterly report showing the dollar volume of all sales under the contract for the previous quarter. Reports are due on the fifteenth (15<sup>th</sup>) day after the close of the previous quarter. It is the responsibility of the awarded vendor to collect and compile all sales under the contract from participating members and submit one (1) report. The report shall include at least the following information as listed in the example below:

Entity Name	Zip Code	State	PO or Job #	Sale Amount

**Total** \_\_\_\_\_

- Each quarter NCPA will invoice the vendor based on the total of sale amount(s) reported. From the invoice the vendor shall pay to NCPA an administrative fee based upon the tiered fee schedule below. Vendor’s annual sales shall be measured on a calendar year basis. Deadline for term of payment will be included in the invoice NCPA provides.

<u>Annual Sales Through Contract</u>	<u>Administrative Fee</u>
0 - \$30,000,000	2%
\$30,000,001 - \$50,000,000	1.5%
\$50,000,001+	1%

- Supplier shall maintain an accounting of all purchases made by Public Agencies under the Master Agreement. NCPA and Region 14 ESC reserve the right to audit the accounting for a

period of four (4) years from the date NCPA receives the accounting. In the event of such an audit, the requested materials shall be provided at the location designated by Region 14 ESC or NCPA. In the event such audit reveals an under reporting of Contract Sales and a resulting underpayment of administrative fees, Vendor shall promptly pay NCPA the amount of such underpayment, together with interest on such amount and shall be obligated to reimburse NCPA's costs and expenses for such audit.

◆ General Provisions

- This Agreement supersedes any and all other agreements, either oral or in writing, between the parties hereto with respect to the subject matter hereof, and no other agreement, statement, or promise relating to the subject matter of this Agreement which is not contained herein shall be valid or binding.
- Awarded vendor agrees to allow NCPA to use their name and logo within website, marketing materials and advertisement. Any use of NCPA name and logo or any form of publicity regarding this contract by awarded vendor must have prior approval from NCPA.
- If any action at law or in equity is brought to enforce or interpret the provisions of this Agreement or to recover any administrative fee and accrued interest, the prevailing party shall be entitled to reasonable attorney's fees and costs in addition to any other relief to which such party may be entitled.
- Neither this Agreement nor any rights or obligations hereunder shall be assignable by Vendor without prior written consent of NCPA, provided, however, that the Vendor may, without such written consent, assign this Agreement and its rights and delegate its obligations hereunder in connection with the transfer or sale of all or substantially all of its assets or business related to this Agreement, or in the event of its merger, consolidation, change in control or similar transaction. Any permitted assignee shall assume all assigned obligations of its assignor under this Agreement.
- This Agreement and NCPA's rights and obligations hereunder may be assigned at NCPA's sole discretion, to an existing or newly established legal entity that has the authority and capacity to perform NCPA's obligations hereunder
- All written communications given hereunder shall be delivered to the addresses as set forth below.

**National Cooperative Purchasing Alliance:**

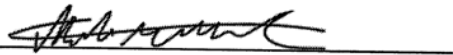
Name: Matthew Mackel  
 Title: Director, Business Development  
 Address: PO Box 701273  
Houston, TX 77270  
 Signature:   
 Date: December 13, 2021

**Vendor:**

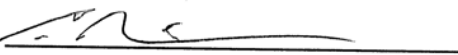
Adaptaspace Inc.  
 Name: Cameron Renkas  
 Title: President  
 Address: 6423-30th Street SE  
Calgary, AB T2C 1R4  
 Signature:   
 Date: December 13, 2021

Adaptaspace takes no exceptions to any of the terms or conditions of this Administration Agreement and will sign the Agreement with no edits if/when awarded a contract.

## TAB 3 – VENDOR QUESTIONNAIRE



**RESPONSE TO REQUEST FOR PROPOSAL  
SUBMITTAL DATE – November 18, 2021**

**Response to Solicitation: 24-21  
Control Room Console Solutions**

# Tab 3 – Vendor Questionnaire

---

Please provide responses to the following questions that address your company’s operations, organization, structure, and processes for providing products and services.

◆ States Covered

- Bidder must indicate any and all states where products and services can be offered.
- Please indicate the price co-efficient for each state if it varies.

**50 States & District of Columbia** (Selecting this box is equal to checking all boxes below)

- |   |   |   |
|---|---|---|
| <input type="checkbox"/> Alabama              | <input type="checkbox"/> Maryland       | <input type="checkbox"/> South Carolina |
| <input type="checkbox"/> Alaska               | <input type="checkbox"/> Massachusetts  | <input type="checkbox"/> South Dakota   |
| <input type="checkbox"/> Arizona              | <input type="checkbox"/> Michigan       | <input type="checkbox"/> Tennessee      |
| <input type="checkbox"/> Arkansas             | <input type="checkbox"/> Minnesota      | <input type="checkbox"/> Texas          |
| <input type="checkbox"/> California           | <input type="checkbox"/> Mississippi    | <input type="checkbox"/> Utah           |
| <input type="checkbox"/> Colorado             | <input type="checkbox"/> Missouri       | <input type="checkbox"/> Vermont        |
| <input type="checkbox"/> Connecticut          | <input type="checkbox"/> Montana        | <input type="checkbox"/> Virginia       |
| <input type="checkbox"/> Delaware             | <input type="checkbox"/> Nebraska       | <input type="checkbox"/> Washington     |
| <input type="checkbox"/> District of Columbia | <input type="checkbox"/> Nevada         | <input type="checkbox"/> West Virginia  |
| <input type="checkbox"/> Florida              | <input type="checkbox"/> New Hampshire  | <input type="checkbox"/> Wisconsin      |
| <input type="checkbox"/> Georgia              | <input type="checkbox"/> New Jersey     | <input type="checkbox"/> Wyoming        |
| <input type="checkbox"/> Hawaii               | <input type="checkbox"/> New Mexico     |   |
| <input type="checkbox"/> Idaho                | <input type="checkbox"/> New York       |   |
| <input type="checkbox"/> Illinois             | <input type="checkbox"/> North Carolina |   |
| <input type="checkbox"/> Indiana              | <input type="checkbox"/> North Dakota   |   |
| <input type="checkbox"/> Iowa                 | <input type="checkbox"/> Ohio           |   |
| <input type="checkbox"/> Kansas               | <input type="checkbox"/> Oklahoma       |   |
| <input type="checkbox"/> Kentucky             | <input type="checkbox"/> Oregon         |   |
| <input type="checkbox"/> Louisiana            | <input type="checkbox"/> Pennsylvania   |   |
| <input type="checkbox"/> Maine                | <input type="checkbox"/> Rhode Island   |   |



**All US Territories and Outlying Areas** (Selecting this box is equal to checking all boxes below)

American Samoa

Northern Marina Islands

Federated States of Micronesia

Puerto Rico

Guam

U.S. Virgin Islands

Midway Islands

◆ **Minority** **and Women**

**Business Enterprise (MWBE) and (HUB) Participation**

- It is the policy of some entities participating in NCPA to involve minority and women business enterprises (MWBE) and historically underutilized businesses (HUB) in the purchase of goods and services. Respondents shall indicate below whether or not they are an M/WBE or HUB certified.

- **Minority / Women Business Enterprise**

- Respondent Certifies that this firm is a M/WBE

- **Historically Underutilized Business**

- Respondent Certifies that this firm is a HUB

◆ **Residency**

- Responding Company's principal place of business is in the city of Calgary, State of Alberta

◆ **Felony Conviction Notice**

- Please Check Applicable Box;

A publically held corporation; therefore, this reporting requirement is not applicable.

Is not owned or operated by anyone who has been convicted of a felony.

Is owned or operated by the following individual(s) who has/have been convicted of a felony

- If the 3<sup>rd</sup> box is checked, a detailed explanation of the names and convictions must be attached.

◆ **Distribution Channel**

- Which best describes your company's position in the distribution channel:

Manufacturer Direct  Certified education/government reseller

Authorized Distributor  Manufacturer marketing through reseller

Value-added reseller  Other: \_\_\_\_\_

◆ **Processing Information**

- Provide company contact information for the following:

- **Sales Reports / Accounts Payable**

Contact Person: Terri Thomas

Title: Office Manager

Company: Adaptaspace Inc.

Address: 6423-30th Street SE

City: Calgary State: Alberta Zip: T2C 1R4

Phone: 403-203-2915 ext 330 Email: tthomas@adaptaspace.com

- Purchase Orders

Contact Person: Cameron Renkas  
Title: President  
Company: Adaptaspace Inc.  
Address: 6423-30th Street SE  
City: Calgary State: Alberta Zip: T2C 1R4  
Phone: 403-203-2915 ext 290 Email: crenkas@adaptaspace.com

- Sales and Marketing

Contact Person: Marie McGinty  
Title: VP Business Development  
Company: Adaptaspace Inc.  
Address: 6423-30th Street SE  
City: Calgary State: Alberta Zip: T2C 1R4  
Phone: 403-203-2915 ext 220 Email: mmcginty@adaptaspace.com

- ◆ Pricing Information

- In addition to the current typical unit pricing furnished herein, the Vendor agrees to offer all future product introductions at prices that are proportionate to Contract Pricing.
  - If answer is no, attach a statement detailing how pricing for NCPA participants would be calculated for future product introductions.  
 Yes       No
- Pricing submitted includes the required NCPA administrative fee. The NCPA fee is calculated based on the invoice price to the customer.  
 Yes       No
- Vendor will provide additional discounts for purchase of a guaranteed quantity.  
 Yes       No

## TAB 4 – VENDOR PROFILE



**RESPONSE TO REQUEST FOR PROPOSAL  
SUBMITTAL DATE – November 18, 2021**

**Response to Solicitation: 24-21  
Control Room Console Solutions**

# Tab 4 – Vendor Profile

Please provide the following information about your company:

- Company’s official registered name.

**Adaptaspace Inc.**

- Brief history of your company, including the year it was established.

**Adaptaspace is a privately-owned corporation based in Calgary, Alberta with sales and support offices located in San Diego, CA, Annapolis, MD, and Montreal, QC. The company’s 45,000 sq. ft. Calgary facility combines its head office, showroom, manufacturing, and assembly operations.**

**Since being formed in 2003, Adaptaspace has been dedicated to the design, manufacture and installation of consoles for ‘Mission Critical’ 24/7 applications, including 911 dispatching and call taking, emergency operations management, process and system control, security and surveillance, traffic management, and technical support.**

**We apply a ‘human-centered’ design approach towards the development of functional and responsive product solutions to the standards of quality, schedule, performance, while keeping costs as low as possible to ensure our customers realize the best value for their investment.**

- Company’s Dun & Bradstreet (D&B) number.

**205119477**

- Company’s organizational chart of those individuals that would be involved in the contract.

## Organization Chart

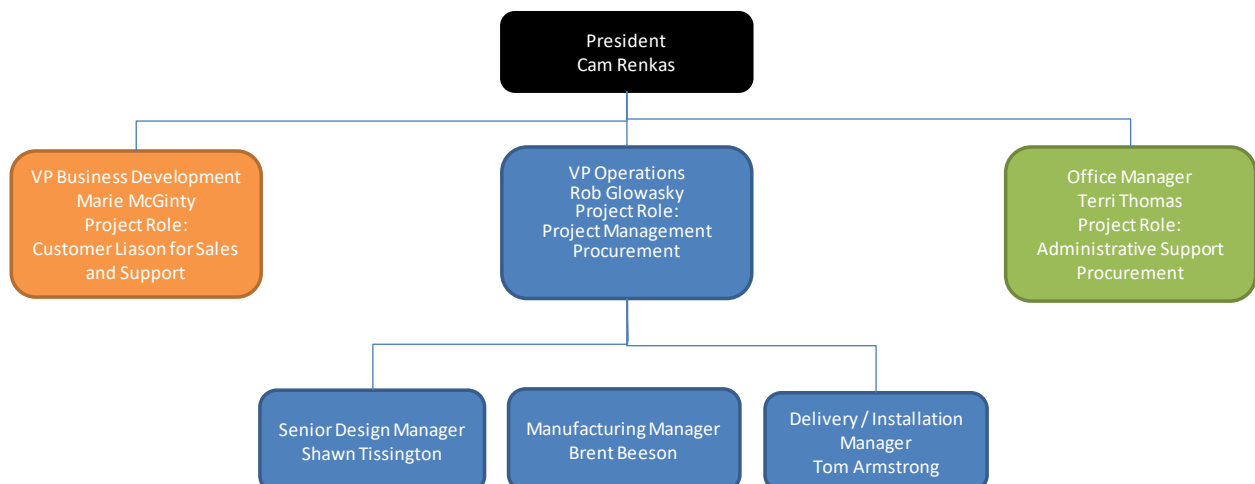

- Corporate office location.

**Head Office and Manufacturing: 6423-30<sup>th</sup> Street SE, Calgary, Alberta T2C 1R4**

- List the number of sales and services offices for states being bid in solicitation.  
**3**
- List the names of key contacts at each with title, address, phone and e-mail address.

**Bill McAllister, Regional Sales Manager US West**  
**10841 Sunset Ridge Dr.**  
**San Diego, CA 92131**  
**858 964 3331**  
**bmcallister@adaptaspace.com**

**Bern Crocker, Regional Sales Manager US East**  
**822 Stonehurst Court**  
**Annapolis, MD 21401**  
**410 349 2030**  
**bcrocker@adaptaspace.com**

**Eugene Armbruster, Regional Sales Manager US South**  
**6423-30<sup>th</sup> Street SE**  
**Calgary, Alberta T2C 1R4**  
**403 888 2855**  
**earmbruster@adaptaspace.com**

- Define your standard terms of payment.

**Net 30 after date of invoice**

- Who is your competition in the marketplace?

**Other console manufacturers**

- What differentiates your company from competitors?

**Unlike our competitors offering catalog-based products, Adaptaspace is a design-based manufacturer offering custom console solutions driven by our customer's specific needs. We have a proven history responding to the challenging design and planning demands of 24/7 control room applications, providing collaborative design support for room layout design, workflow analysis, console design development, and equipment requirements.**

**A key difference from office furniture or workstation products is that our consoles are**

**designed to last 20+ years and are backed by our industry leading Lifetime Warranty, which provides exceptional value for our customers.**

**Our dedication to providing the highest level of on-site support from concept development and project planning phases through production, start-up, and post installation is a core value of Adaptspace that positions us uniquely in the industry.**

- Describe how your company will market this contract if awarded.

**Adaptspace will market the contract on our website, in our email signature, through digital marketing to selected procurement groups and through our sales team. Our sales team will discuss the benefits of purchasing through a cooperative agreement directly with customers.**

- Describe how you intend to introduce NCPA to your company.

**Our sales team will be introduced to the NCPA during one of our monthly sales meetings.**

- Describe your firm's capabilities and functionality of your on-line catalog / ordering website.

**Adaptspace does not have an on-line catalog or ordering website. We work directly with our customers to ensure their specific needs are met using our modular and customizable console systems.**

- Describe your company's Customer Service Department (hours of operation, number of service centers, etc.)

**Adaptspace's Customer Support is available from 8:00 am to 5:00 pm Monday – Friday. All technical and warranty support is initially provided through our head office to troubleshoot the issue and provide a service resolution plan. If on-site support is required, Adaptspace will send a technician from one of our installation partners located throughout the US.**

**In addition to our industry leading warranty, Adaptspace is committed to providing long term support to every product installation. We regularly respond to a variety of parts and service requests in support of clients wishing to implement minor equipment changes and upgrades, or major reconfigurations.**

- Green Initiatives
  - As our business grows, we want to make sure we minimize our impact on the Earth's climate. We are taking every step we can to implement innovative and responsible environmental practices throughout NCPA to reduce our carbon footprint, reduce waste, energy conservation, ensure efficient computing and much more. To that effort we ask respondents to provide their companies environmental policy and/or green initiative.

**At Adaptspace, we strongly believe that it is our responsibility to design, manufacture and deliver products that will not only reduce the impact on the environment, but also be friendly to its users. Products we design, processes we use in our manufacturing and in our offices, materials we incorporate in our products, and subcontractors we employ are all selected to a great extent for their contribution to improve our environment.**

## **SUSTAINABLE PROCESSES**

**From electronic document submissions to the selection of green products, Adaptaspace is always looking for processes that improve our environmental impact. We have worked with our suppliers to eliminate paper orders, reduce or eliminate non-recyclable packaging materials and take advantage of environmentally friendly products where possible. By sourcing materials locally, we are able to reduce fuel and transportation requirements. All paper, plastic, cardboard, printer ink cartridges, and scrap metal (including shavings), are recycled; and pallets from suppliers are returned or re-used.**

## **SUSTAINABLE MATERIALS**

**Adaptaspace uses sustainable materials in all of its products including but not limited to Steel, Aluminium, Wood, Textiles and Adhesives. Our standard laminate offering is manufactured by Wilsonart, which is Greenguard certified, has low VOC emitting and includes 22% recycled materials; particle board used in work surfaces and panels is 100% recycled; Medium Density Fiber panels are derived from MPB (Mountain Pine Beetle) damaged trees; all wood is procured within 500 miles from Calgary; fabric is 100% recycled and recyclable. In addition, we use water based adhesives for laminates and fabrics; environmentally friendly cleaning solutions; and powder coat paints which do not emit VOC's.**

- Vendor Certifications (if applicable)
  - Provide a copy of all current licenses, registrations and certifications issued by federal, state and local agencies, and any other licenses, registrations or certifications from any other governmental entity with jurisdiction, allowing respondent to perform the covered services including, but not limited to, licenses, registrations, or certifications. Certifications can include M/WBE, HUB, and manufacturer certifications for sales and service.

**Not Applicable**

## TAB 5 – PRODUCTS AND SERVICES / SCOPE



**RESPONSE TO REQUEST FOR PROPOSAL  
SUBMITTAL DATE – November 18, 2021**

**Response to Solicitation: 24-21  
Control Room Console Solutions**



# Tab 5 – Products and Services

---

- Respondent shall perform and provide these products and/or services under the terms of this agreement. The supplier shall assist the end user with making a determination of their individual needs.

**Adaptaspace will provide all products and services noted below under the terms of the agreement. Adaptaspace works closely with its customers to provide collaborative design support for room layout design, workflow analysis, console design development, and equipment requirements.**

**Standard project support services include:**

- **Planning Support— concepts, budgeting**
- **Requirements Analysis — criteria & constraints, key success factors**
- **Detailed Drawings and Specifications**
- **Conceptual Design Development — renderings, prototypes**
- **Delivery & Installation Planning**

**Adaptaspace consoles are uniquely designed and configured to support each customer’s specific functional needs, equipment requirements and facility layout constraints, all feature the following common elements:**

- **optimized human factors for increased comfort and reduced physical stress**
  - **equipment and accessory mounting flexibility to satisfy the needs of each user**
  - **extensive cable management for easy installation and access**
  - **power and data connections to support each user**
  - **product durability for 24 hours / 7-day operation**
  - **room layout flexibility to cater to any spatial constraints**
  - **modularity to allow for future equipment and room layout re-configurations**
  - **attractive aesthetics to reflect corporate identity and image**
- The following is a list of suggested (but not limited to) Control Room Console Solutions categories. List all categories along with manufacturer that you are responding with:
    - **Console Workstations – Manufactured by Adaptaspace**
    - **Monitor Support Arms – Manufactured by Innovative Design Works and/or Humanscale**
    - **Task Lights – Manufactured by Konzept Lighting and/or Humanscale**
    - **Complementary Millwork – Manufactured by Adaptaspace**
    - **Storage – Manufactured by Adaptaspace**

- Desktop Electrical – **Manufactured by Adaptaspace and/or Byrne Electrical**
- Turret Panels – **Manufactured by Adaptaspace**
- Personal Environment Systems – **Manufactured by Adaptaspace**
- Unique equipment – **Manufactured by Adaptaspace**
- 24/7 Operator Chairs - **Manufactured by Lifeform Chairs and/or Humanscale**
- Delivery - **Provided by Adaptaspace**
- Installation – **Provided by Adaptaspace**

**Detailed descriptions of each product and service are provided below:**

## **1. CONSOLE WORKSTATIONS**

Adaptaspace PROCESS console workstations are configured to comply with ergonomic standards established by ISO, BIFMA, ADA, ANSI and CSA.

Each standard console features a Modular Sub-Frame with Ventilated Equipment Mounting Enclosures, Internal Power Distribution and Cable Management System, a Seamless Work Surface with our Flex-Rail Rear Mounting Beam supporting Modular Monitor Mounting Supports configured for various monitor configurations specified by the end user. Optional height adjustable work surfaces are available, as well as console accessories such as Task Lighting, Personal Environment Comfort Systems, Desktop Power/Data Convenience Outlets, Equipment Cabinet Cooling Fans, Slide-Out Shelves and Cabinet Lighting, and many other items.

Each console is designed in conformance with established North American ergonomic standards from the following organizations, where applicable:

- ADA (Americans with Disabilities Act)
- ANSI (American National Standards Institute) Human Factors
- CSA (Canadian Standards Institute)
- OSHA (Occupational Safety and Health Administration)
- BIFMA (Business and Institutional Furniture Manufacturers Association)
- UL (Underwriters Laboratory)

Materials and products used in Adaptaspace consoles are either low or no-VOC emitting. Each relevant individual component is Greenguard certified, including particleboard, laminates, fabrics, powder coating, and adhesives.

Adaptaspace consoles offer the highest level of retrofit capability. At any time after initial installation the console layouts can be easily reconfigured without the need for on-site cutting, drilling, or machining.

### **1.1 CONSOLE BASE FRAME EQUIPMENT CABINET**

- The console base frame is freestanding and consists of a structural steel and aluminum framework utilizing a unified frame construction design that ties each element of the console substructure into a contiguous whole, stabilizing all movement.

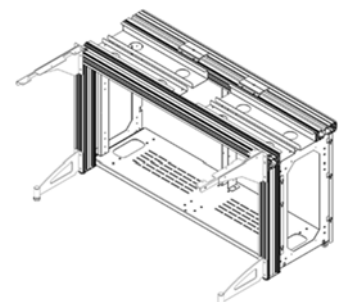

- Console levelers provide up to 1-3/4" (44mm) of adjustment to accommodate uneven floor conditions.
- All heavy gauge sheet metal and structural extrusions shall be finished with an exceptionally durable electrostatic powder coat finish. The base frame will include integrated horizontal and vertical cable management.
- Structural extrusions shall be constructed of thick wall, custom profile extruded aluminum. The structural extrusions shall be cut to length within a manufacturing tolerance of linear +0, -1/32", angular +/- 0.25 degrees
- Other structural components such as processor cabinet frames and structural gussets shall be CNC precision-tooled 12-14 gauge cold-rolled steel. Manufacturing tolerances on the structural sheet metal components are linear +/- 0.020", angular +/- 0.25 degrees.

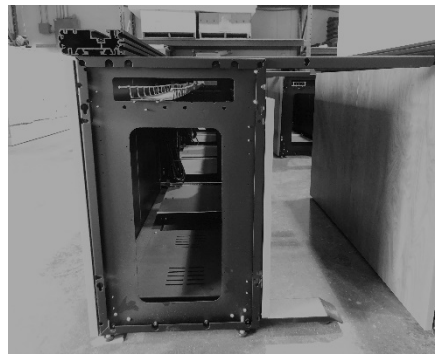
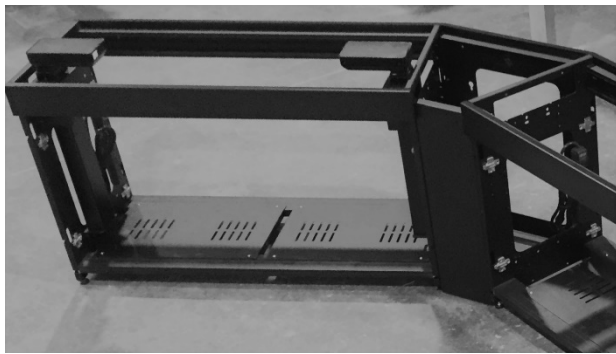

## 1.2 EXTERIOR PANELS AND DOORS

- All exterior panels and access doors are constructed of 11/16" industrial grade particleboard with high pressure laminate (HPL) surfaces (front) and PVC edges. Optional powder-coated metal panels and doors can be provided.
- All access panels and doors shall have concealed hinges for easy access to equipment and quick removal if necessary.
- Optional locks can be provided if required. Locks can be keyed alike or independently.
- Optional Rear Privacy Panels can be provided for an acoustic solution for control rooms, increasing privacy for operators, and improving safety by reducing contact between personnel.
  - Privacy panels can be mounted across the rear of the console equipment cabinet modules set to a fixed height or the panels can be mounted to the rear work surface so that they move with the operator through sitting and standing positions.
  - Privacy panels are installed with a powder-coated aluminum frame system. The front and rear panels can be constructed with high pressure plastic laminate (HPL) exteriors to match the console finishes, fabric wrapped tackable cores for improved acoustics, or a combination of both.

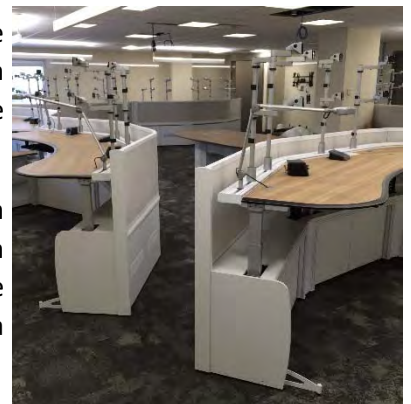

### 1.3 WORK SURFACES

The console work surface will provide a smooth level workspace with no gaps and comply with accepted human factors criteria.

- All ergonomic standards are been taken into consideration including knee well space (434mm), foot depth clearance (589mm), monitor view/reach distances (740mm) and keyboard surface height (572mm min to 1219mm max).
- Work surfaces are constructed with 1" (25.4mm) industrial grade high-density particle board core material with high pressure laminate (HPL) surfaces (top and bottom) and pre-applied HPL edges.
- The console work surfaces are supported by 12-gauge steel cantilevered support arms and formed support beams. Work surfaces have been successfully tested to support a static load of 100lbs/lineal foot.
- The keyboard work surface front edge (nosing) has an ergonomic "waterfall" sloped molded rubber edge to ensure operator comfort and eliminate contact stress. The nosing shall be constructed of high impact, non-porous molded rubber using a one piece profile, eliminating the potential for separation, wrinkling, and damage, which is inherent in a soft urethane over aluminum frame nosing system, and a better compliment for anti-microbial surfaces.

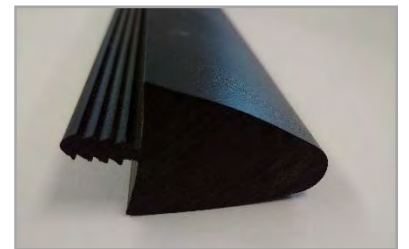

### 1.4 OPTIONAL SIT/STAND LIFT SYSTEM

All Adaptaspace consoles can be provided with optional height adjustable work surfaces. The sit/stand lift system is designed to be capable of lifting all required work surface area including monitors and other equipment that may be placed on top of or attached to each work surface. Adaptaspace uses only Linak products - widely recognized as the industry leader in electric linear actuator technology systems - in our PROCESS consoles.

- Each work surface is attached to multiple Linak DL6 lifting columns (each DL6 has a 264 lbs. (120 kg) lifting capacity) that are rigidly mounted to the console base frame.
- Speed of travel under load is 1.75" per second and is virtually silent. The system is equipped with integrated anti-collision protection that will sense any interfering object and will halt and reverse.
- Each lift actuator can be expected to run for 10,000 cycles; a cycle meaning a full stroke up and then down at full load based on 10% duty cycle.
- Sufficient space (minimum of 1-1/4") shall be allowed between passing objects (and between the equipment and work surface elements) such that pinch points do not exist.
- The standard range of travel for the work surface is set to a minimum of 28.5" (724mm) and to a maximum of 54" (1372mm), but alternate heights can be provided
- Height adjustment of each surface is controlled by an integrated digital smart switch mounted under the work surface within easy reach of the operator. Each switch features a digital readout display, Bluetooth connection to smart devices, four favorite positions, and a color changing light strip to remind users to stand.



## 1.5 INTERNAL EQUIPMENT MOUNTING

The base cabinet of each console provides a series of integrated storage compartments with adequate ventilation airflow to allow for equipment storage, easily accessed for maintenance through the hinged front and rear door panels.

- Consoles are designed to have sufficient equipment cabinet space to accommodate all necessary equipment such as computers, switches, radios, etc. with capacity for future equipment expansion.
- The processor cabinets have fixed equipment shelves, but optional heavy-duty slide-out shelves are available for allowing easy maintenance access to all equipment.
- Optional ventilation grills for additional passive ventilation are available and optional automatic, thermal controlled cooling fans (rated with 23 CFM of airflow and a noise rating of 27 dBA) can be provided for active ventilation if needed.
- Optional interior cabinet lighting is also available.



## 1.6 CABLE MANAGEMENT

Each console has integrated cable management providing continuous horizontal and vertical cable management allowing logical, discrete routing, and splitting of power and data cables throughout the entire console without obstruction.

Adaptaspace's open frame design allows power and data to be routed from the floor into the console interior.

4" wide by 1" deep horizontal sheet metal cable trays allow for wires to enter/exit at any point along the length of the tray with no need for fishing of cables and provide separation between AC power distribution and data/audio network cabling.

Vertical cable management chains are provided on all consoles with height adjustable work surfaces that extend and retract with the up/down movement of the sit/stand work surface and protect the cables from entanglement and pinching.

Grommets are provided on the rear of the work surfaces to route desktop cables to the underside of the work surfaces. Cables are then routed into the vertical cable management chains and brought down into the horizontal cable trays located in the console modules.



## 1.7 POWER DISTRIBUTION

Adaptaspace consoles include all internal AC power distribution. Standard power distribution is provided with UL certified surge protected power distribution bars, but optional hard-wired configurations are available.

Power bars are mounted in the equipment cabinets, as well as under the work surface to support all desktop power requirements to minimize the cables moving up and down with the work surface. Power bars are sized with sufficient outlets to support all equipment, and can be 15 amp or 20 amp.

Drawings and reference information representing the proposed electrical distribution will be submitted to the customer for review and approval prior to fabrication.

## 2. MONITOR SUPPORT ARMS

One of the more critical elements of console design is the monitor mounting system and how users interact with the displays. Adaptaspace consoles all include our FLEX-RAIL Mounting Beam system on the rear of the work surface which allows for maximum flexibility in positioning or reconfiguring the monitor arm positions across the length of the console.

Each console is designed to accommodate all required monitors, configured across a single tier or across two or even three tiers. Monitors can be mounted to individual arms allowing the most adjustability for operators or to a monitor array that sets a large group of monitors at a specific alignment and depth. Adaptaspace's FLEX-RAIL Mounting Beam can even support large screen displays up to 70".

Each individual monitor arms can be positioned anywhere along the length of the console and can support a maximum weight per monitor of 69 lbs. Each arm includes quick release brackets and VESA mounting plates, and provides:

- 10" of vertical height adjustment and 14" of arm extension
- 360 degrees of monitor swivel for landscape or portrait viewing
- 200 degrees of monitor tilt



One of the unique advantages of this system is that monitor arms can be easily added, removed or repositioned, providing simple reconfiguration of the console as equipment needs change or evolve.

We offer monitor arrays that can support up to 12 monitors with a maximum weight of 40 lbs per monitor. Each array includes quick release brackets and VESA mounting plates, along with fine tuning adjustments for perfect alignment of displays.



## 3. TASK LIGHTS

### DESKTOP TASK LIGHTING

Adaptaspace offers multiple desktop task light options from a variety of manufacturers. The lights can be permanently mounted to the front or rear work surface, attached to the Flex-Rail mounting beam, or mounted to a moveable base for maximum flexibility in positioning or reconfiguring the task light position.

Our standard option is the Humanscale 'Element 790' task light which come with an industry leading 10-year 24/7 use warranty. The Element 790 is a triple articulating, dimmable LED task light with 28" of reach and a warm 3500K color temperature.



The 'Z-Bar' by Koncept Lighting is another popular task light option. The Z-Bar offers highly functional triple articulation with 32" of reach and a 360 degree head rotation. This dimmable, 9.5W LED task light comes in a 4500K cool light or a 3500K warm light, both with a 50,000 hr life and a 5-year, 24/7 use warranty.

Final lighting positions are determined through the design process to ensure the lighting is positioned to effectively illuminate the work surface area and supplement the available ambient light levels.

### **SITUATIONAL AWARENESS LIGHT**

Adaptaspace can provide situational awareness lights mounted on a light pole when required. Our standard Patlite 40mm diameter LED tower indicator light comes with up to 4 multi-colored lamps and is mounted to the Flex-Rail rear mounting beam so that it moves up and down with the operator in the sitting or standing position. Each pole can have optional position identifiers that can be easily changed.



### **AMBIENT MONITOR LIGHTING**

Optional ambient LED strip lighting can be provided under the console surface to add lighting to dim control rooms and/or behind the monitors to help minimize eye strain for the operators.

## **4. COMPLEMENTARY MILLWORK**

To complement the base console workstation solution, Adaptaspace can provide custom millwork options for the control room, for consideration through the final design development phase of the project:

- Built-in storage cabinets with filing drawers (legal or letter), standard drawers and/or binder shelves
- Kitchen type cabinetry to support sinks, under surface bar fridges, drawers and storage shelves if these amenities are needed in the control room
- Meeting/collaboration tables

Our millwork is designed to withstand the rigors of 24/7 use and are constructed with industrial grade, high-density particle board core material and high-pressure laminate (HPL) surfaces (top and bottom). Construction will include PVC edging colors to match consoles and levelers provide up to 1-3/4" (44mm) of adjustment to accommodate uneven floor conditions. Cabinets include 110° hinged doors with decorative arched pulls, adjustable shelving, and cable grommets. Optional solid surface or stainless steel countertops are available.

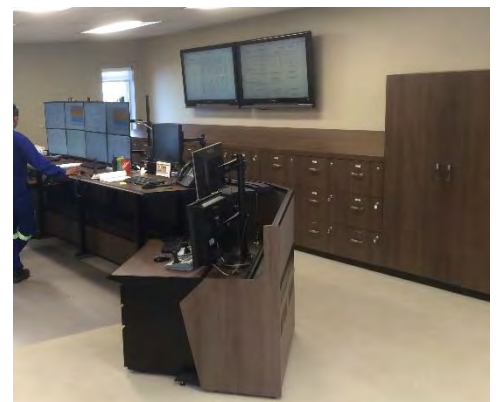
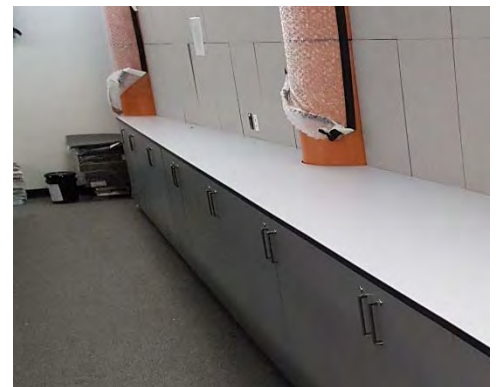

## 5. STORAGE

Adaptaspace provides a variety of custom storage solutions that can be integrated with the console or freestanding within the control room:

- Freestanding storage cabinets with filing drawers (legal or letter), standard drawers and/or binder shelves
- Desktop mounted binder shelves or bookcases
- Lazy Susan binder carousels
- Map cabinets
- Printer cabinets or tables

Our storage units are designed to withstand the rigors of 24/7 use and are constructed with industrial grade, high-density particle board core material and high-pressure laminate (HPL) surfaces (top and bottom). Construction will include PVC edging colors to match consoles and levelers provide up to 1-3/4" (44mm) of adjustment to accommodate uneven floor conditions. Cabinets include 110° hinged doors with decorative arched pulls, adjustable shelving, and cable grommets.

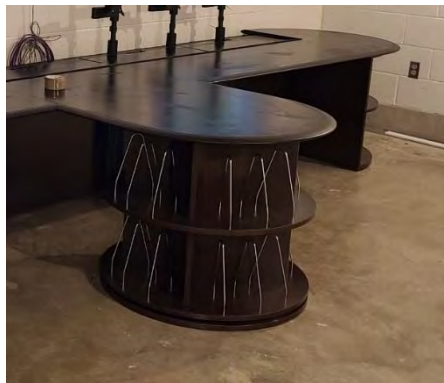

## 6. DESKTOP ELECTRICAL

Adaptaspace offers a variety of desktop convenience hubs that are integrated into the console if requested. Each hub can include any combination of the following:

- 15amp/120V power outlets
- USB 2amp charging ports
- USB 2.0 or 3.0 data passthrough
- Cat5 or Cat6 network ports
- RJ11 phone ports
- HDMI or DVI video ports
- 3.5mm audio headset ports





## 7. TURRET PANELS

Adaptaspace can provide desktop turret panels with emergency stop buttons, indicator lights and levels, and alarm speakers. Turrets are constructed with powder coated sheet metal structures or millwork structures to match the console finishes.

Each turret is custom designed for the specific project requirements and can be provided fully wired to a sub-panel within the console or with blank faceplates for on-site wiring. Sheet metal faceplates are removable and can be provided with lamacoid labels.



## 8. PERSONAL ENVIRONMENT SYSTEM

Each console can be equipped with Adaptaspace's ClimatePlus™ Personal Environment Control System. ClimatePlus™ utilizes two (2) desktop diffuser fan units with up to 100 CFM of airflow and a user interface control unit that controls ventilation fan speed, task lights, white noise sound masking, and heat On/Off.

- The user interface unit has a power indicator light and an occupancy sensor for automatic shutoff. If user returns within 60 minutes of automatic shutoff, the system will resume all functions at previous settings.
- ClimatePlus™ fan units have been designed to be small enough to not interfere with the view of monitors, while providing 100 CFM of airflow with 2.5" round adjustable air diffusers and a washable filter.
- The fan units have brackets allowing them to be mounted in a fixed position on the work surface or they can be left as freestanding units for user flexibility.
- A 170-watt radiant-heat panel is recessed into the front panel under the console work surface and effectively warms the knee-space area to the user's preference. An optional 250 watt forced air heater is also available.



## 9. UNIQUE EQUIPMENT

Adaptaspace can provide custom designed parts, shelves and mounts to be incorporated into the console, such as radio shelves, rack mounts, speaker mounts, overhead lighting and Sound Shower enclosures, large screen display mounts, etc. There is virtually no limit on what can be provided.

## 10. 24/7 OPERATOR CHAIRS

Adaptaspace offers a variety of operator chairs from Humanscale, Lifeform and Concept Seating. These operator chairs differ from standard office chairs in that they are designed and warranted for 24/7 multi-shift use. Operator chairs also offer higher weight capacities, as well as larger, roomier seat pans and ergonomic support for longer shifts.

## TAB 8 – VALUE ADDED PRODUCTS AND SERVICES



**RESPONSE TO REQUEST FOR PROPOSAL  
SUBMITTAL DATE – November 18, 2021**

**Response to Solicitation: 24-21  
Control Room Console Solutions**

## Tab 8 – Value Added Products and Services

---

- ◆ Include any additional products and/or services available that vendor currently performs in their normal course of business that is not included in the scope of the solicitation that you think will enhance and add value to this contract for Region 14 ESC and all NCPA participating entities.

No additional products or services

## TAB 9 – REQUIRED DOCUMENTS



**RESPONSE TO REQUEST FOR PROPOSAL  
SUBMITTAL DATE – November 18, 2021**

**Response to Solicitation: 24-21  
Control Room Console Solutions**

# Tab 9 – Required Documents

---

- ◆ Clean Air and Water Act / Debarment Notice
- ◆ Contractors Requirements
- ◆ Antitrust Certification Statements
- ◆ Required Clauses for Federal Funds Certifications
- ◆ Required Clauses for Federal Assistance by FTA
- ◆ State Notice Addendum

## Clean Air and Water Act & Debarment Notice

I, the Vendor, am in compliance with all applicable standards, orders or regulations issued pursuant to the Clean Air Act of 1970, as Amended (42 U.S. C. 1857 (h), Section 508 of the Clean Water Act, as amended (33 U.S.C. 1368), Executive Order 117389 and Environmental Protection Agency Regulation, 40 CFR Part 15 as required under OMB Circular A-102, Attachment O, Paragraph 14 (1) regarding reporting violations to the grantor agency and to the United States Environment Protection Agency Assistant Administrator for the Enforcement.

I hereby further certify that my company has not been debarred, suspended or otherwise ineligible for participation in Federal Assistance programs under Executive Order 12549, "Debarment and Suspension", as described in the Federal Register and Rules and Regulations

Potential Vendor	Adaptaspace Inc.
Print Name	Cameron Renkas
Address	6423-30th Street SE
City, State, Zip	Calgary, Alberta T2C 1R4
Authorized signature	
Date	November 17, 2021

## Contractor Requirements

### **Contractor Certification Contractor's Employment Eligibility**

By entering the contract, Contractor warrants compliance with the Federal Immigration and Nationality Act (FINA), and all other federal and state immigration laws and regulations. The Contractor further warrants that it is in compliance with the various state statutes of the states it is will operate this contract in.

Participating Government Entities including School Districts may request verification of compliance from any Contractor or subcontractor performing work under this Contract. These Entities reserve the right to confirm compliance in accordance with applicable laws.

Should the Participating Entities suspect or find that the Contractor or any of its subcontractors are not in compliance, they may pursue any and all remedies allowed by law, including, but not limited to: suspension of work, termination of the Contract for default, and suspension and/or debarment of the Contractor. All costs necessary to verify compliance are the responsibility of the Contractor.

The offeror complies and maintains compliance with the appropriate statutes which requires compliance with federal immigration laws by State employers, State contractors and State subcontractors in accordance with the E-Verify Employee Eligibility Verification Program.

Contractor shall comply with governing board policy of the NCPA Participating entities in which work is being performed

#### **Fingerprint & Background Checks**

If required to provide services on school district property at least five (5) times during a month, contractor shall submit a full set of fingerprints to the school district if requested of each person or employee who may provide such service. Alternately, the school district may fingerprint those persons or employees. An exception to this requirement may be made as authorized in Governing Board policy. The district shall conduct a fingerprint check in accordance with the appropriate state and federal laws of all contractors, subcontractors or vendors and their employees for which fingerprints are submitted to the district. Contractor, subcontractors, vendors and their employees shall not provide services on school district properties until authorized by the District.

The offeror shall comply with fingerprinting requirements in accordance with appropriate statutes in the state in which the work is being performed unless otherwise exempted.

Contractor shall comply with governing board policy in the school district or Participating Entity in which work is being performed

#### **Business Operations in Sudan, Iran**

In accordance with A.R.S. 35-391 and A.R.S. 35-393, the Contractor hereby certifies that the contractor does not have scrutinized business operations in Sudan and/or Iran.

Authorized signature

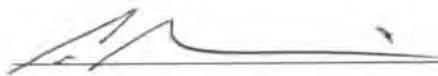

Date

November 17, 2021

## Antitrust Certification Statements (Tex. Government Code § 2155.005)

I affirm under penalty of perjury of the laws of the State of Texas that:

- (1) I am duly authorized to execute this contract on my own behalf or on behalf of the company, corporation, firm, partnership or individual (Company) listed below;
- (2) In connection with this bid, neither I nor any representative of the Company has violated any provision of the Texas Free Enterprise and Antitrust Act, Tex. Bus. & Comm. Code Chapter 15;
- (3) In connection with this bid, neither I nor any representative of the Company has violated any federal antitrust law; and
- (4) Neither I nor any representative of the Company has directly or indirectly communicated any of the contents of this bid to a competitor of the Company or any other company, corporation, firm, partnership or individual engaged in the same line of business as the Company.

Company name	Adaptaspace Inc.
Address	6423-30th Street SE
City/State/Zip	Calgary, Alberta T2C 1R4
Telephone No.	403-203-2915 ext 290
Fax No.	403-203-0142
Email address	crenkas@adaptaspace.com
Printed name	Cameron Renkas
Position with company	President
Authorized signature	



## **Required Clauses for Federal Funds Certifications**

Participating Agencies may elect to use federal funds to purchase under the Master Agreement. The following certifications and provisions may be required and apply when a Participating Agency expends federal funds for any purchase resulting from this procurement process. Pursuant to 2 C.F.R. § 200.326, all contracts, including small purchases, awarded by the Participating Agency and the Participating Agency's subcontractors shall contain the procurement provisions of Appendix II to Part 200, as applicable.

### **APPENDIX II TO 2 CFR PART 200**

(A) Contracts for more than the simplified acquisition threshold currently set at \$150,000, which is the inflation adjusted amount determined by the Civilian Agency Acquisition Council and the Defense Acquisition Regulations Council (Councils) as authorized by 41 U.S.C. 1908, must address administrative, contractual, or legal remedies in instances where contractors violate or breach contract terms, and provide for such sanctions and penalties as appropriate.

(B) Termination for cause and for convenience by the grantee or subgrantee including the manner by which it will be effected and the basis for settlement. (All contracts in excess of \$10,000)

(C) Equal Employment Opportunity. Except as otherwise provided under 41 CFR Part 60, all contracts that meet the definition of "federally assisted construction contract" in 41 CFR Part 60-1.3 must include the equal opportunity clause provided under 41 CFR 60-1.4(b), in accordance with Executive Order 11246, "Equal Employment Opportunity" (30 CFR 12319, 12935, 3 CFR Part, 1964-1965 Comp., p. 339), as amended by Executive Order 11375, "Amending Executive Order 11246 Relating to Equal Employment Opportunity," and implementing regulations at 41 CFR part 60, "Office of Federal Contract Compliance Programs, Equal Employment Opportunity, Department of Labor."

Pursuant to Federal Rule (C) above, when a Participating Agency expends federal funds on any federally assisted construction contract, the equal opportunity clause is incorporated by reference herein.

(D) Davis-Bacon Act, as amended (40 U.S.C. 3141-3148). When required by Federal program legislation, all prime construction contracts in excess of \$2,000 awarded by non-Federal entities must include a provision for compliance with the Davis-Bacon Act (40 U.S.C. 3141-3144, and 3146-3148) as supplemented by Department of Labor regulations (29 CFR Part 5, "Labor Standards Provisions Applicable to Contracts Covering Federally Financed and Assisted Construction"). In accordance with the statute, contractors must be required to pay wages to laborers and mechanics at a rate not less than the prevailing wages specified in a wage determination made by the Secretary of Labor. In addition, contractors must be required to pay wages not less than once a week. The non-Federal entity must place a copy of the current prevailing wage determination issued by the Department of Labor in each solicitation. The decision to award a contract or subcontract must be conditioned upon the acceptance of the wage determination. The non-Federal entity must report all suspected or reported violations to the Federal awarding agency. The contracts must also include a provision

for compliance with the Copeland “Anti-Kickback” Act (40 U.S.C. 3145), as supplemented by Department of Labor regulations (29 CFR Part 3, “Contractors and Subcontractors on Public Building or Public Work Financed in Whole or in Part by Loans or Grants from the United States”). The Act provides that each contractor or subrecipient must be prohibited from inducing, by any means, any person employed in the construction, completion, or repair of public work, to give up any part of the compensation to which he or she is otherwise entitled. The non-Federal entity must report all suspected or reported violations to the Federal awarding agency.

(E) Contract Work Hours and Safety Standards Act (40 U.S.C. 3701-3708). Where applicable, all contracts awarded by the non-Federal entity in excess of \$100,000 that involve the employment of mechanics or laborers must include a provision for compliance with 40 U.S.C. 3702 and 3704, as supplemented by Department of Labor regulations (29 CFR Part 5). Under 40 U.S.C. 3702 of the Act, each contractor must be required to compute the wages of every mechanic and laborer on the basis of a standard work week of 40 hours. Work in excess of the standard work week is permissible provided that the worker is compensated at a rate of not less than one and a half times the basic rate of pay for all hours worked in excess of 40 hours in the work week. The requirements of 40 U.S.C. 3704 are applicable to construction work and provide that no laborer or mechanic must be required to work in surroundings or under working conditions which are unsanitary, hazardous or dangerous. These requirements do not apply to the purchases of supplies or materials or articles ordinarily available on the open market, or contracts for transportation or transmission of intelligence.

(F) Rights to Inventions Made Under a Contract or Agreement. If the Federal award meets the definition of “funding agreement” under 37 CFR §401.2 (a) and the recipient or subrecipient wishes to enter into a contract with a small business firm or nonprofit organization regarding the substitution of parties, assignment or performance of experimental, developmental, or research work under that “funding agreement,” the recipient or subrecipient must comply with the requirements of 37 CFR Part 401, “Rights to Inventions Made by Nonprofit Organizations and Small Business Firms Under Government Grants, Contracts and Cooperative Agreements,” and any implementing regulations issued by the awarding agency.

(G) Clean Air Act (42 U.S.C. 7401-7671q.) and the Federal Water Pollution Control Act (33 U.S.C. 1251-1387), as amended— Contracts and subgrants of amounts in excess of \$150,000 must contain a provision that requires the non-Federal award to agree to comply with all applicable standards, orders or regulations issued pursuant to the Clean Air Act (42 U.S.C. 7401- 7671q) and the Federal Water Pollution Control Act as amended (33 U.S.C. 1251- 1387). Violations must be reported to the Federal awarding agency and the Regional Office of the Environmental Protection Agency (EPA).

(H) Debarment and Suspension (Executive Orders 12549 and 12689)—A contract award (see 2 CFR 180.220) must not be made to parties listed on the government wide exclusions in the System for Award Management (SAM), in accordance with the OMB guidelines at 2 CFR 180 that implement Executive Orders 12549 (3 CFR part 1986 Comp., p. 189) and 12689 (3 CFR part 1989 Comp., p. 235), “Debarment and Suspension.” SAM Exclusions contains the names of parties debarred, suspended, or otherwise excluded by agencies, as well as parties declared ineligible under statutory or regulatory authority other than Executive Order 12549.

(I) Byrd Anti-Lobbying Amendment (31 U.S.C. 1352)—Contractors that apply or bid for an award exceeding \$100,000 must file the required certification. Each tier certifies to the tier above that it will not and has not used Federal appropriated funds to pay any person or organization for influencing or attempting to influence an officer or employee

of any agency, a member of Congress, officer or employee of Congress, or an employee of a member of Congress in connection with obtaining any Federal contract, grant or any other award covered by 31 U.S.C. 1352. Each tier must also disclose any lobbying with non-Federal funds that takes place in connection with obtaining any Federal award. Such disclosures are forwarded from tier to tier up to the non-Federal award.

#### **RECORD RETENTION REQUIREMENTS FOR CONTRACTS INVOLVING FEDERAL FUNDS**

When federal funds are expended by Participating Agency for any contract resulting from this procurement process, offeror certifies that it will comply with the record retention requirements detailed in 2 CFR § 200.333. The offeror further certifies that offeror will retain all records as required by 2 CFR § 200.333 for a period of three years after grantees or subgrantees submit final expenditure reports or quarterly or annual financial reports, as applicable, and all other pending matters are closed.

#### **CERTIFICATION OF COMPLIANCE WITH THE ENERGY POLICY AND CONSERVATION ACT**

When Participating Agency expends federal funds for any contract resulting from this procurement process, offeror certifies that it will comply with the mandatory standards and policies relating to energy efficiency which are contained in the state energy conservation plan issued in compliance with the Energy Policy and Conservation Act (42 U.S.C. 6321 et seq.; 49 C.F.R. Part 18).

#### **CERTIFICATION OF COMPLIANCE WITH BUY AMERICA PROVISIONS**

To the extent purchases are made with Federal Highway Administration, Federal Railroad Administration, or Federal Transit Administration funds, offeror certifies that its products comply with all applicable provisions of the Buy America Act and agrees to provide such certification or applicable waiver with respect to specific products to any Participating Agency upon request. Purchases made in accordance with the Buy America Act must still follow the applicable procurement rules calling for free and open competition.

# **Required Clauses for Federal Assistance provided by FTA**

## **ACCESS TO RECORDS AND REPORTS**

Contractor agrees to:

- a) Maintain all books, records, accounts and reports required under this Contract for a period of not less than three (3) years after the date of termination or expiration of this Contract or any extensions thereof except in the event of litigation or settlement of claims arising from the performance of this Contract, in which case Contractor agrees to maintain same until Public Agency, the FTA Administrator, the Comptroller General, or any of their duly authorized representatives, have disposed of all such litigation, appeals, claims or exceptions related thereto.
- b) Permit any of the foregoing parties to inspect all work, materials, payrolls, and other data and records with regard to the Project, and to audit the books, records, and accounts with regard to the Project and to reproduce by any means whatsoever or to copy excerpts and transcriptions as reasonably needed for the purpose of audit and examination.

*FTA does not require the inclusion of these requirements of Article 1.01 in subcontracts. Reference 49 CFR 18.39 (i)(11).*

## **CIVIL RIGHTS / TITLE VI REQUIREMENTS**

- 1) Non-discrimination. In accordance with Title VI of the Civil Rights Act of 1964, as amended, 42 U.S.C. § 2000d, Section 303 of the Age Discrimination Act of 1975, as amended, 42 U.S.C. § 6102, Section 202 of the Americans with Disabilities Act of 1990, as amended, 42 U.S.C. § 12132, and Federal Transit Law at 49 U.S.C. § 5332, Contractor or subcontractor agrees that it will not discriminate against any employee or applicant for employment because of race, color, creed, national origin, sex, marital status age, or disability. In addition, Contractor agrees to comply with applicable Federal implementing regulations and other implementing requirements FTA may issue.
- 2) Equal Employment Opportunity. The following Equal Employment Opportunity requirements apply to this Contract:
  - a. Race, Color, Creed, National Origin, Sex. In accordance with Title VII of the Civil Rights Act, as amended, 42 U.S.C. § 2000e, and Federal Transit Law at 49 U.S.C. § 5332, the Contractor agrees to comply with all applicable Equal Employment Opportunity requirements of U.S. Dept. of Labor regulations, "Office of Federal Contract Compliance Programs, Equal Employment Opportunity, Department of Labor, 41 CFR, Parts 60 et seq., and with any applicable Federal statutes, executive orders, regulations, and Federal policies that may in the future affect construction activities undertaken in the course of this Project. Contractor agrees to take affirmative action to ensure that applicants are employed, and that employees are treated during employment, without regard to their race, color, creed, national origin, sex, marital status, or age. Such action shall include, but not be limited to, the following: employment, upgrading, demotion or transfer, recruitment or recruitment advertising, layoff or termination, rates of pay or other forms of compensation; and selection for training, including apprenticeship. In addition, Contractor agrees to comply with any implementing requirements FTA may issue.
  - b. Age. In accordance with the Age Discrimination in Employment Act (ADEA) of 1967, as amended, 29 U.S.C. Sections 621 through 634, and Equal Employment Opportunity Commission (EEOC) implementing regulations, "Age Discrimination in Employment Act", 29 CFR Part 1625, prohibit employment discrimination by Contractor against individuals on the basis of age, including present and prospective

employees. In addition, Contractor agrees to comply with any implementing requirements FTA may issue.

- c. Disabilities. In accordance with Section 102 of the Americans with Disabilities Act of 1990, as amended (ADA), 42 U.S.C. Sections 12101 *et seq.*, prohibits discrimination against qualified individuals with disabilities in programs, activities, and services, and imposes specific requirements on public and private entities. Contractor agrees that it will comply with the requirements of the Equal Employment Opportunity Commission (EEOC), "Regulations to Implement the Equal Employment Provisions of the Americans with Disabilities Act," 29 CFR, Part 1630, pertaining to employment of persons with disabilities and with their responsibilities under Titles I through V of the ADA in employment, public services, public accommodations, telecommunications, and other provisions.
  - d. Segregated Facilities. Contractor certifies that their company does not and will not maintain or provide for their employees any segregated facilities at any of their establishments, and that they do not and will not permit their employees to perform their services at any location under the Contractor's control where segregated facilities are maintained. As used in this certification the term "segregated facilities" means any waiting rooms, work areas, restrooms and washrooms, restaurants and other eating areas, parking lots, drinking fountains, recreation or entertainment areas, transportation, and housing facilities provided for employees which are segregated by explicit directive or are in fact segregated on the basis of race, color, religion or national origin because of habit, local custom, or otherwise. Contractor agrees that a breach of this certification will be a violation of this Civil Rights clause.
- 3) Solicitations for Subcontracts, Including Procurements of Materials and Equipment. In all solicitations, either by competitive bidding or negotiation, made by Contractor for work to be performed under a subcontract, including procurements of materials or leases of equipment, each potential subcontractor or supplier shall be notified by Contractor of Contractor's obligations under this Contract and the regulations relative to non-discrimination on the grounds of race, color, creed, sex, disability, age or national origin.
  - 4) Sanctions of Non-Compliance. In the event of Contractor's non-compliance with the non-discrimination provisions of this Contract, Public Agency shall impose such Contract sanctions as it or the FTA may determine to be appropriate, including, but not limited to: 1) Withholding of payments to Contractor under the Contract until Contractor complies, and/or; 2) Cancellation, termination or suspension of the Contract, in whole or in part.

*Contractor agrees to include the requirements of this clause in each subcontract financed in whole or in part with Federal assistance provided by FTA, modified only if necessary to identify the affected parties.*

### **DISADVANTAGED BUSINESS PARTICIPATION**

This Contract is subject to the requirements of Title 49, Code of Federal Regulations, Part 26, "*Participation by Disadvantaged Business Enterprises in Department of Transportation Financial Assistance Programs*", therefore, it is the policy of the Department of Transportation (DOT) to ensure that Disadvantaged Business Enterprises (DBEs), as defined in 49 CFR Part 26, have an equal opportunity to receive and participate in the performance of DOT-assisted contracts.

- 1) Non-Discrimination Assurances. Contractor or subcontractor shall not discriminate on the basis of race, color, national origin, or sex in the performance of this Contract. Contractor shall carry out all applicable requirements of 49 CFR Part 26 in the award and administration of DOT-assisted contracts. Failure by Contractor to carry out these requirements is a material breach of this Contract, which may result in the termination of this Contract or other such remedy as public agency deems appropriate. Each subcontract Contractor signs with a subcontractor must include the assurance in this paragraph. (See 49 CFR 26.13(b)).

- 2) Prompt Payment. Contractor is required to pay each subcontractor performing Work under this prime Contract for satisfactory performance of that work no later than thirty (30) days after Contractor's receipt of payment for that Work from public agency. In addition, Contractor is required to return any retainage payments to those subcontractors within thirty (30) days after the subcontractor's work related to this Contract is satisfactorily completed and any liens have been secured. Any delay or postponement of payment from the above time frames may occur only for good cause following written approval of public agency. This clause applies to both DBE and non-DBE subcontractors. Contractor must promptly notify public agency whenever a DBE subcontractor performing Work related to this Contract is terminated or fails to complete its Work, and must make good faith efforts to engage another DBE subcontractor to perform at least the same amount of work. Contractor may not terminate any DBE subcontractor and perform that Work through its own forces, or those of an affiliate, without prior written consent of public agency.
- 3) DBE Program. In connection with the performance of this Contract, Contractor will cooperate with public agency in meeting its commitments and goals to ensure that DBEs shall have the maximum practicable opportunity to compete for subcontract work, regardless of whether a contract goal is set for this Contract. Contractor agrees to use good faith efforts to carry out a policy in the award of its subcontracts, agent agreements, and procurement contracts which will, to the fullest extent, utilize DBEs consistent with the efficient performance of the Contract.

### **ENERGY CONSERVATION REQUIREMENTS**

Contractor agrees to comply with mandatory standards and policies relating to energy efficiency which are contained in the State energy conservation plans issued under the Energy Policy and Conservation Act, as amended, 42 U.S.C. Sections 6321 *et seq.* and 41 CFR Part 301-10.

### **FEDERAL CHANGES**

Contractor shall at all times comply with all applicable FTA regulations, policies, procedures and directives, including without limitation those listed directly or by reference in the Contract between public agency and the FTA, as they may be amended or promulgated from time to time during the term of this contract. Contractor's failure to so comply shall constitute a material breach of this Contract.

### **INCORPORATION OF FEDERAL TRANSIT ADMINISTRATION (FTA) TERMS**

The provisions include, in part, certain Standard Terms and Conditions required by the U.S. Department of Transportation (DOT), whether or not expressly set forth in the preceding Contract provisions. All contractual provisions required by the DOT, as set forth in the most current FTA Circular 4220.1F, dated November 1, 2008, are hereby incorporated by reference. Anything to the contrary herein notwithstanding, all FTA mandated terms shall be deemed to control in the event of a conflict with other provisions contained in this Contract. Contractor agrees not to perform any act, fail to perform any act, or refuse to comply with any public agency requests that would cause public agency to be in violation of the FTA terms and conditions.

### **NO FEDERAL GOVERNMENT OBLIGATIONS TO THIRD PARTIES**

Agency and Contractor acknowledge and agree that, absent the Federal Government's express written consent and notwithstanding any concurrence by the Federal Government in or approval of the solicitation or award of the underlying Contract, the Federal Government is not a party to this Contract and shall not be subject to any obligations or liabilities to agency, Contractor, or any other party (whether or not a party to that contract) pertaining to any matter resulting from the underlying Contract.

*Contractor agrees to include the above clause in each subcontract financed in whole or in part with federal assistance provided by the FTA. It is further agreed that the clause shall not be modified, except to identify the subcontractor who will be subject to its provisions.*

#### **PROGRAM FRAUD AND FALSE OR FRAUDULENT STATEMENTS**

Contractor acknowledges that the provisions of the Program Fraud Civil Remedies Act of 1986, as amended, 31 U.S.C. §§ 3801 et seq. and U.S. DOT regulations, "Program Fraud Civil Remedies," 49 CFR Part 31, apply to its actions pertaining to this Contract. Upon execution of the underlying Contract, Contractor certifies or affirms the truthfulness and accuracy of any statement it has made, it makes, it may make, or causes to be made, pertaining to the underlying Contract or the FTA assisted project for which this Contract Work is being performed.

In addition to other penalties that may be applicable, Contractor further acknowledges that if it makes, or causes to be made, a false, fictitious, or fraudulent claim, statement, submission, or certification, the Federal Government reserves the right to impose the penalties of the Program Fraud Civil Remedies Act of 1986 on Contractor to the extent the Federal Government deems appropriate.

Contractor also acknowledges that if it makes, or causes to be made, a false, fictitious, or fraudulent claim, statement, submission, or certification to the Federal Government under a contract connected with a project that is financed in whole or in part with Federal assistance originally awarded by FTA under the authority of 49 U.S.C. § 5307, the Government reserves the right to impose the penalties of 18 U.S.C. § 1001 and 49 U.S.C. § 5307 (n)(1) on the Contractor, to the extent the Federal Government deems appropriate.

*Contractor agrees to include the above clauses in each subcontract financed in whole or in part with Federal assistance provided by FTA. It is further agreed that the clauses shall not be modified, except to identify the subcontractor who will be subject to the provisions.*

## **State Notice Addendum**

The National Cooperative Purchasing Alliance (NCPA), on behalf of NCPA and its current and potential participants to include all county, city, special district, local government, school district, private K-12 school, higher education institution, state, tribal government, other government agency, healthcare organization, nonprofit organization and all other Public Agencies located nationally in all fifty states, issues this Request for Proposal (RFP) to result in a national contract.

For your reference, the links below include some, but not all, of the entities included in this proposal:

[http://www.usa.gov/Agencies/State\\_and\\_Territories.shtml](http://www.usa.gov/Agencies/State_and_Territories.shtml)

<https://www.usa.gov/local-governments>