



# Data Sheet

## Granite EPIK



Granite EPIK offers a POTS alternative that is fully compatible with alarm, POS and voice lines, and provides savings along with the best service in the industry. Our patented technology is delivered over the 4G LTE network, with intelligent failover to internet or PRI connections for redundancy. Granite EPIK offers universal US availability, even at locations no longer served by traditional copper circuits.

Based on a Class 5 Softswitch, the Granite EPIK Edge device fully emulates a central office, delivering service quality and reliability – and allowing alarm providers a code-compliant network handoff for existing fire or intrusion panels and enabling compliance with both HIPAA and PCI standards.

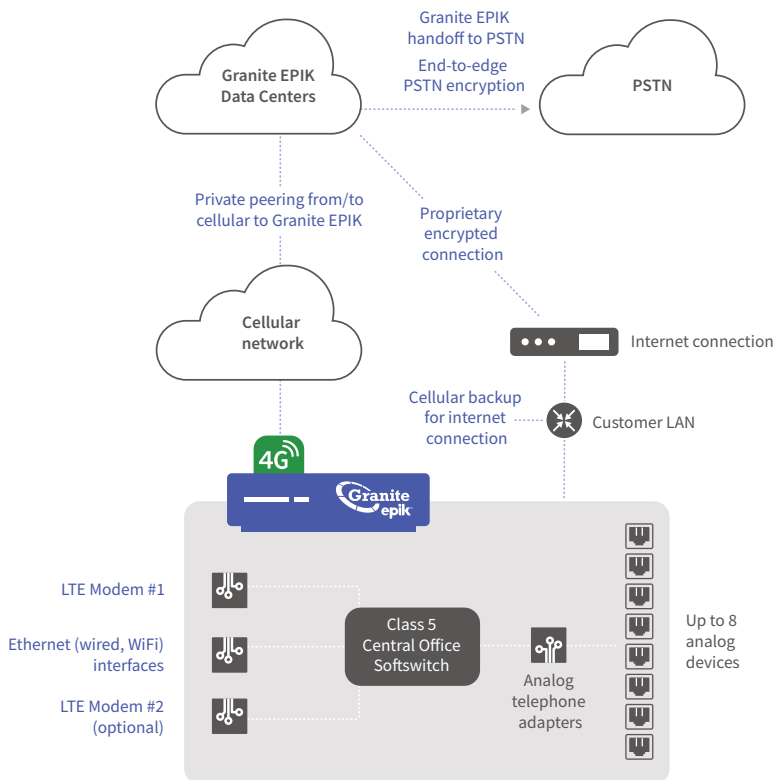

Choice of cellular, wired Ethernet, WiFi or PRI as primary network connectivity, with automatic failover to any option.

Using cellular, device can provide backup LAN internet connectivity.

### Key benefits

- Compatible with virtually all analog line devices, including alarm panels (protocols include Contact ID, 4x2 and SIA), POS, elevators, FSK-enabled modem and fax
- Fire and building code compliant
- More reliable than traditional POTS with 24-hour battery backup, optional dual SIMs, and intelligent failover to PRI or internet connection\*
- 24/7 remote out-of-band monitoring with instant notification for critical alarm and voice circuits
- Cellular backup to maintain site connectivity if primary internet access is unavailable
- Advanced security with end-to-edge encryption on calls and faxes
- PCI compliant for payments, POS and other financial transactions
- HIPAA compliant for medical, pharmacy and insurance environments
- Toll-free and existing DID numbers can be ported or new numbers assigned
- Advanced voice features including ringdown (auto dial when phone goes off-hook), forwarding, hunt groups and voicemail
- Cost savings of up to 30%

\*Some jurisdictions may require wireline connections for certain applications (Fire/Life Safety), and wireline connections may be necessary to furnish service at some locations.

## Solution capabilities

### Traditional analog line compatibility

Granite EPIK includes a Class 5 Central Office switch that supports traditional analog lines, including ones that are not compatible with other SIP-based or wireless solutions.

- Meets or exceeds national, state and local building and fire codes
- Approved for Life Safety applications, including fire and burglar panels, elevators, escalators and other alarm systems
- Complies with National Fire Protection Association (NFPA) 72 as a Managed Facility-based Voice Network (MFVN)
- Tested and accepted by leading fire and burglar panel manufacturers as satisfying their technical standards

Compatible with virtually all analog fax devices:

- Transmit and receive, including long-form and high-volume faxes
- Unique store-and-forward capability ensures greater than 99% fax deliverability
- HIPAA compliant with end-to-edge fax encryption

### Monitoring and reporting

The Granite EPIK portal provides a dashboard view of device status, call detail activity and fax transmissions. Benefit from 24/7 monitoring with real-time email, SMS or voice notification of network status, power loss, backup battery status and environmental conditions.

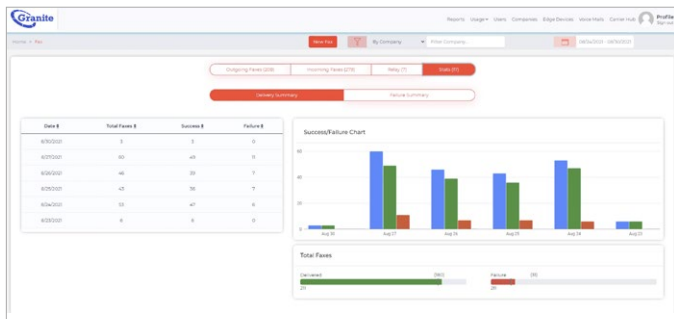

At-a-glance fax deliverability reports show summary statistics by selected time period.

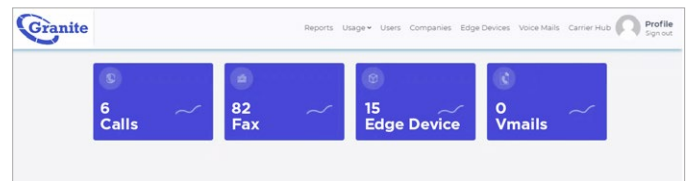
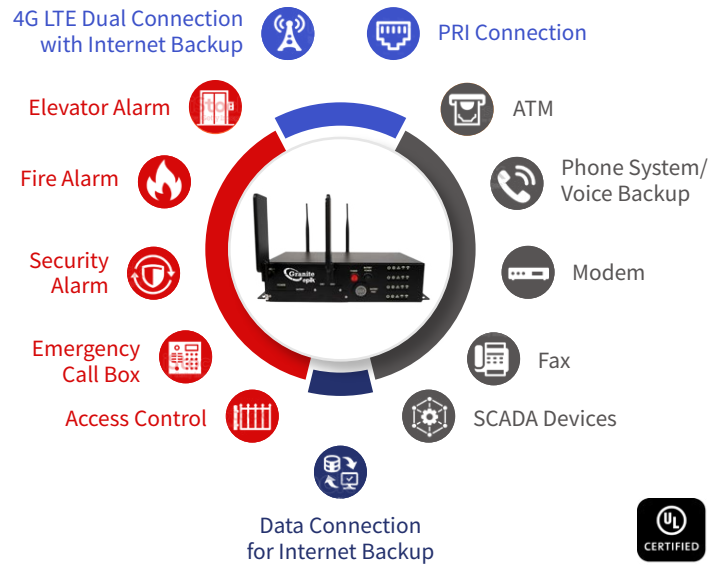

See key metrics at the enterprise or device level.

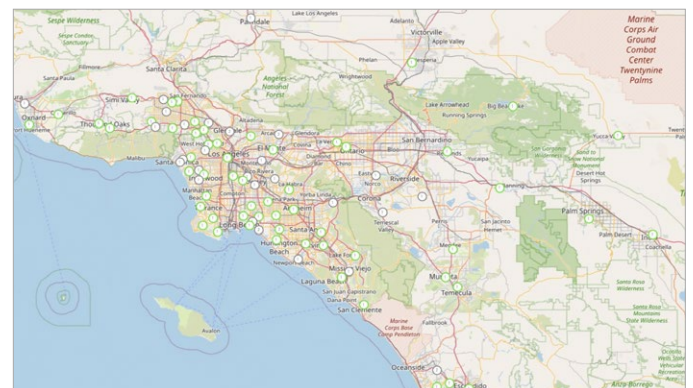

View real-time device status.

**Front**

Granite EPIK Gen3

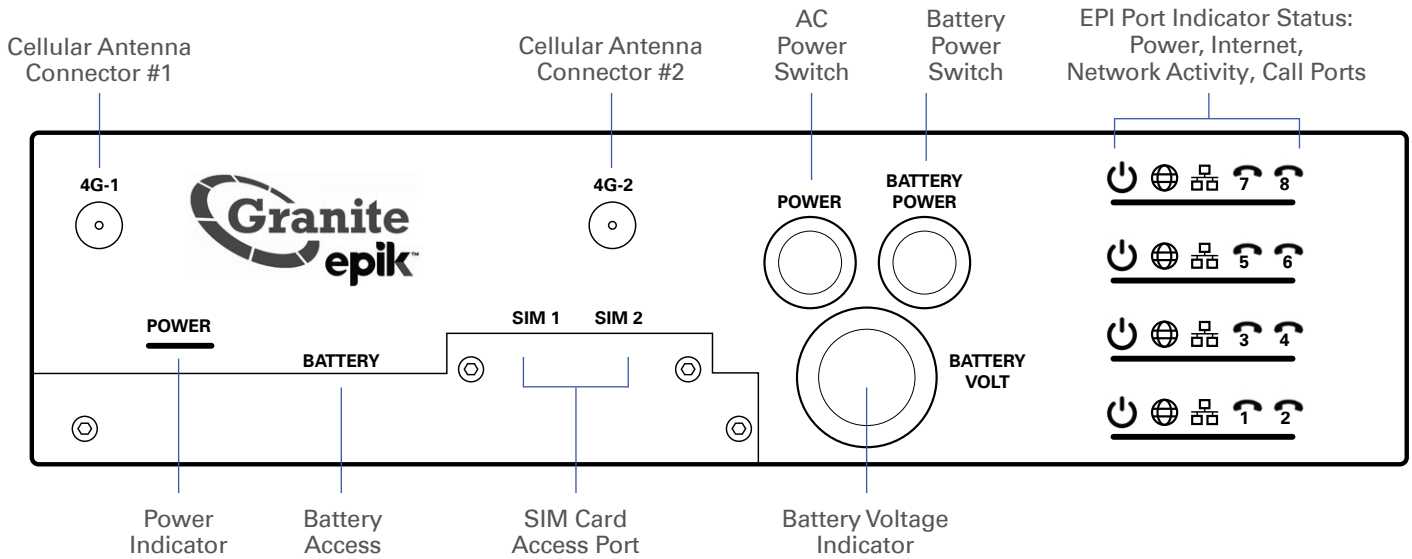

**Back**

Granite EPIK Gen3

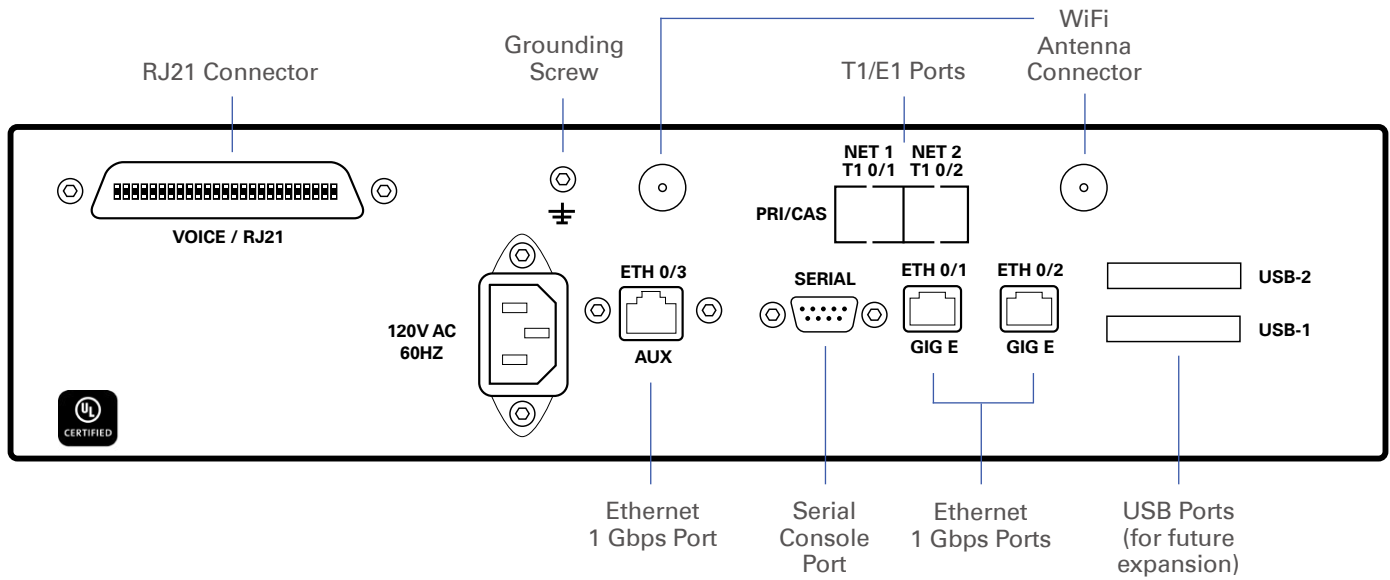

## Technical Specifications

Physical	
Dimensions	13.6" (L) x 6.44" (W) x 3.37" (H) Height including cellular antennas: 8.75" Height including WiFi antennas: 9.25"
Weight	8 lbs
Mounting	Desk, wall/shelf or rack mounted (2U)
Case	Black steel extrusion Fanless, vented
CPU	AMD Embedded, quad-core processor
RAM	8 GB
Power	
AC Input	120 VAC
AC Frequency	60 Hz
AC Current	1.6 A
Internal battery	11.1 VDC 10400 mAh Lithium Ion Field replaceable 24 hours standby usage 8 hours under full line usage
Battery alarm	Integrated low battery and no charge alert and notification
UPS system	Supports UPS extended battery backup
Environmental	
Operating temperature	-20° C to +70° C (-4° F to +158° F) Integrated environmental alert and notification
Storage temperature	-20° C to +85° C (-4° F to +185° F)
Operating humidity	20% to 90% non-condensing
Radios	
WiFi	Dual WiFi antennas (removable, SMA connector) WiFi 2.4 GHz (802.11 b/g/n, MIMO 300 Mbps) WiFi 5 GHz (802.11 a/an/ac, MIMO 867 Mbps)
Cellular LTE	Dual 4G antennas (removable, SMA connector) Dual SIM slots (Micro SIM 15 mm x 12mm 3FF) Dual path capable LTE CAT 4, CAT 6 (optional), 5G capable Verizon and T-Mobile networks QoS protocol enables priority access to private 4G networks LTE Bands: - FDD B2[1900], B4[1700], B5[850], B12[700], B13[700], B14[700], B66[1700], B71[600] - DC-HSPA+

All specifications subject to change

\*Some jurisdictions may require wireline connections for certain applications (Fire/Life Safety), and wireline connections may be necessary to furnish service at some locations.

Interfaces	
Ports	Male Amphenol RJ21 connector (up to 8 line FXO/FXS capable), direct punch down to 66 block or 8 individual RJ11 jacks 3X 1 Gbps Ethernet (software configurable as WAN or LAN ports) Male DB-9 serial port console connector Grounding screw 2X PRI T1/E1, CAS/super trunk (optional)
Optional expansion unit	24 FXS ports
LEDs and notifications (front)	Power indicator Internal battery "on" indicator Battery voltage indicator EPI port status indicators (1, 2 or 4, depending on model): power, internet, network activity, 2X call ports
Switches	Primary power (AC) Battery power switch (DC)
Analog device compatibility	Voice, fax, alarm line, SCADA, modem, DTMF

Security and encryption	
IoT firewall	Yes, stateful
End-to-edge voice encryption	Yes
Signaling protocol	Proprietary
VLAN capable	Yes

Regulatory and compliance approvals	
<ul style="list-style-type: none"> <li>Complies with NFPA 72 (National Fire Protection Association) for fire alarms</li> <li>Certified as MFVN (Managed Facilities-based Voice Network)</li> <li>Tested extensively and accepted by leading fire and burglar panel manufacturers</li> </ul>	<ul style="list-style-type: none"> <li>Approved for other Fire/Life Safety applications, including elevators, escalators and other alarm systems*</li> <li>HIPAA and PCI compliant</li> <li>RoHS</li> <li>UL 62133; UL 62368</li> </ul> 

Included accessories	
<ul style="list-style-type: none"> <li>North America power cord</li> <li>Wall mount screw pack</li> <li>Rubber feet for desktop mounting</li> </ul>	<ul style="list-style-type: none"> <li>10' Amphenol RJ21 cable</li> <li>66 block and brackets</li> <li>Installation guide</li> </ul>

Optional accessories	
<ul style="list-style-type: none"> <li>Rack mounted kit</li> </ul>	

Country of origin	Patent status
Assembled in USA	US Patent 10,986,555 (filed September 25, 2019; issued April 20, 2021)