

Region 4 Education Service Center (ESC)

Contract # R210502

for

Modular Buildings, Portable Storage, and Relocatable Walkways

with

TSG Industries

Effective: October 1, 2021

The following documents comprise the executed contract between the Region 4 Education Service Center and TSG Industries, effective October 1, 2021:

- I. Vendor Contract and Signature Form
- II. Supplier's Response to the RFP, incorporated by reference

CONTRACT

This Contract (“Contract”) is made as of October 1, 2021 by and between TSG Industries (“Contractor”) and Region 4 Education Service Center (“Region 4 ESC”) for the purchase of Modular Buildings, Portable Storage, and Relocatable Walkways (“the products and services”).

RECITALS

WHEREAS, Region 4 ESC issued Request for Proposals Number R 21-05 for Modular Buildings, Portable Storage, and Relocatable Walkways (“RFP”), to which Contractor provided a response (“Proposal”); and

WHEREAS, Region 4 ESC selected Contractor’s Proposal and wishes to engage Contractor in providing the services/materials described in the RFP and Proposal;

WHEREAS, both parties agree and understand the following pages will constitute the Contract between the Contractor and Region 4 ESC, having its principal place of business at 7145 West Tidwell Road, Houston, TX 77092.

WHEREAS, Contractor included, in writing, any required exceptions or deviations from these terms, conditions, and specifications; and it is further understood that, if agreed to by Region 4 ESC, said exceptions or deviations are incorporated into the Contract.

WHEREAS, this Contract consists of the provisions set forth below, including provisions of all attachments referenced herein. In the event of a conflict between the provisions set forth below and those contained in any attachment, the provisions set forth below shall control.

WHEREAS, the Contract will provide that any state and local governmental entities, public and private primary, secondary and higher education entities, non-profit entities, and agencies for the public benefit (“Public Agencies”) may purchase products and services at prices indicated in the Contract upon the Public Agency’s registration with OMNIA Partners.

1) Term of agreement. The term of the Contract is for a period of three (3) years unless terminated, canceled or extended as otherwise provided herein. Region 4 ESC shall have the right to renew the Contract for two (2) additional one-year periods or portions thereof. Region 4 ESC shall review the Contract prior to the renewal date and notify the Contractor of Region 4 ESC’s intent renew the Contract. Contractor may elect not to renew by providing three hundred sixty-five days’ (365) notice to Region 4 ESC. Notwithstanding the expiration of the initial term or any subsequent term or all renewal options, Region 4 ESC and Contractor may mutually agree to extend the term of this Agreement. Contractor acknowledges and understands Region 4 ESC is under no obligation whatsoever to extend the term of this Agreement. The Contract shall have the right to enter local “service” agreements with Participating Public Agencies accessing this Agreement, so long as the effective date of such agreement is prior to the expiration of this Agreement. All local agreements may have a full potential term (any combination of initial and renewal periods) not to exceed five (5) years.

- 2) Scope: Contractor shall perform all duties, responsibilities and obligations, set forth in this agreement, and described in the RFP, incorporated herein by reference as though fully set forth herein.
- 3) Form of Contract. The form of Contract shall be the RFP, the Offeror's proposal and Best and Final Offer(s).
- 4) Order of Precedence. In the event of a conflict in the provisions of the Contract as accepted by Region 4 ESC, the following order of precedence shall prevail:
 - i. This Contract
 - ii. Offeror's Best and Final Offer
 - iii. Offeror's proposal
 - iv. RFP and any addenda
- 5) Commencement of Work. The Contractor is cautioned not to commence any billable work or provide any material or service under this Contract until Contractor receives a purchase order for such work or is otherwise directed to do so in writing by Region 4 ESC.
- 6) Entire Agreement (Parol evidence). The Contract, as specified above, represents the final written expression of agreement. All agreements are contained herein and no other agreements or representations that materially alter it are acceptable.
- 7) Assignment of Contract. No assignment of Contract may be made without the prior written approval of Region 4 ESC. Contractor is required to notify Region 4 ESC when any material change in operations is made (i.e. bankruptcy, change of ownership, merger, etc.).
- 8) Novation. If Contractor sells or transfers all assets or the entire portion of the assets used to perform this Contract, a successor in interest must guarantee to perform all obligations under this Contract. Region 4 ESC reserves the right to accept or reject any new party. A change of name agreement will not change the contractual obligations of Contractor.
- 9) Contract Alterations. No alterations to the terms of this Contract shall be valid or binding unless authorized and signed by Region 4 ESC.
- 10) Adding Authorized Distributors/Dealers. Contractor is prohibited from authorizing additional distributors or dealers, other than those identified at the time of submitting their proposal, to sell under the Contract without notification and prior written approval from Region 4 ESC. Contractor must notify Region 4 ESC each time it wishes to add an authorized distributor or dealer. Purchase orders and payment can only be made to the Contractor unless otherwise approved by Region 4 ESC. Pricing provided to members by added distributors or dealers must also be less than or equal to the Contractor's pricing.
- 11) TERMINATION OF CONTRACT
 - a) Cancellation for Non-Performance or Contractor Deficiency. Region 4 ESC may terminate the Contract if purchase volume is determined to be low volume in any 12-month period. Region 4 ESC reserves the right to cancel the whole or any part of this Contract due to failure by Contractor to carry out any obligation, term or condition of the contract. Region 4 ESC may issue a written deficiency notice to Contractor for acting or failing to act in any of the following:

- i. Providing material that does not meet the specifications of the Contract;
- ii. Providing work or material was not awarded under the Contract;
- iii. Failing to adequately perform the services set forth in the scope of work and specifications;
- iv. Failing to complete required work or furnish required materials within a reasonable amount of time;
- v. Failing to make progress in performance of the Contract or giving Region 4 ESC reason to believe Contractor will not or cannot perform the requirements of the Contract; or
- vi. Performing work or providing services under the Contract prior to receiving an authorized purchase order.

Upon receipt of a written deficiency notice, Contractor shall have ten (10) days to provide a satisfactory response to Region 4 ESC. Failure to adequately address all issues of concern may result in Contract cancellation. Upon cancellation under this paragraph, all goods, materials, work, documents, data and reports prepared by Contractor under the Contract shall immediately become the property of Region 4 ESC.

- b) Termination for Cause. If, for any reason, Contractor fails to fulfill its obligation in a timely manner, or Contractor violates any of the covenants, agreements, or stipulations of this Contract Region 4 ESC reserves the right to terminate the Contract immediately and pursue all other applicable remedies afforded by law. Such termination shall be effective by delivery of notice, to the Contractor, specifying the effective date of termination. In such event, all documents, data, studies, surveys, drawings, maps, models and reports prepared by Contractor will become the property of the Region 4 ESC. If such event does occur, Contractor will be entitled to receive just and equitable compensation for the satisfactory work completed on such documents.
- c) Delivery/Service Failures. Failure to deliver goods or services within the time specified, or within a reasonable time period as interpreted by the purchasing agent or failure to make replacements or corrections of rejected articles/services when so requested shall constitute grounds for the Contract to be terminated. In the event Region 4 ESC must purchase in an open market, Contractor agrees to reimburse Region 4 ESC, within a reasonable time period, for all expenses incurred.
- d) Force Majeure. If by reason of Force Majeure, either party hereto shall be rendered unable wholly or in part to carry out its obligations under this Agreement then such party shall give notice and full particulars of Force Majeure in writing to the other party within a reasonable time after occurrence of the event or cause relied upon, and the obligation of the party giving such notice, so far as it is affected by such Force Majeure, shall be suspended during the continuance of the inability then claimed, except as hereinafter provided, but for no longer period, and such party shall endeavor to remove or overcome such inability with all reasonable dispatch.

The term Force Majeure as employed herein, shall mean acts of God, strikes, lockouts, or other industrial disturbances, act of public enemy, orders of any kind of government of the United States or the State of Texas or any civil or military authority; insurrections; riots; epidemics; landslides; lighting; earthquake; fires; hurricanes; storms; floods; washouts; droughts; arrests; restraint of government and people; civil disturbances; explosions, breakage or accidents to machinery, pipelines or canals, or other causes not reasonably within the control of the party claiming such inability. It is understood and agreed that the settlement of strikes and lockouts shall be entirely within the discretion of the party having the difficulty, and that the above requirement that any Force Majeure shall be remedied with all reasonable dispatch shall not require the settlement of strikes and lockouts by acceding to the demands of the opposing party or parties when such settlement is unfavorable in the judgment of the party having the difficulty.

- e) Standard Cancellation. Region 4 ESC may cancel this Contract in whole or in part by providing written notice. The cancellation will take effect 30 business days after the other party receives the notice of cancellation. After the 30th business day all work will cease following completion of final purchase order.
- 12) Licenses. Contractor shall maintain in current status all federal, state and local licenses, bonds and permits required for the operation of the business conducted by Contractor. Contractor shall remain fully informed of and in compliance with all ordinances and regulations pertaining to the lawful provision of services under the Contract. Region 4 ESC reserves the right to stop work and/or cancel the Contract if Contractor's license(s) expire, lapse, are suspended or terminated.
- 13) Survival Clause. All applicable software license agreements, warranties or service agreements that are entered into between Contractor and Region 4 ESC under the terms and conditions of the Contract shall survive the expiration or termination of the Contract. All Purchase Orders issued and accepted by Contractor shall survive expiration or termination of the Contract.
- 14) Delivery. Conforming product shall be shipped within 7 days of receipt of Purchase Order. If delivery is not or cannot be made within this time period, the Contractor must receive authorization for the delayed delivery. The order may be canceled if the estimated shipping time is not acceptable. All deliveries shall be freight prepaid, F.O.B. Destination and shall be included in all pricing offered unless otherwise clearly stated in writing.
- 15) Inspection & Acceptance. If defective or incorrect material is delivered, Region 4 ESC may make the determination to return the material to the Contractor at no cost to Region 4 ESC. The Contractor agrees to pay all shipping costs for the return shipment. Contractor shall be responsible for arranging the return of the defective or incorrect material.
- 16) Payments. Payment shall be made after satisfactory performance, in accordance with all provisions thereof, and upon receipt of a properly completed invoice.
- 17) Price Adjustments. Should it become necessary or proper during the term of this Contract to make any change in design or any alterations that will increase price, Region 4 ESC must be notified immediately. Price increases must be approved by Region 4 ESC and no payment for additional materials or services, beyond the amount stipulated in the Contract shall be paid without prior approval. All price increases must be supported by manufacturer documentation, or a formal cost justification letter. Contractor must honor previous prices for thirty (30) days after approval and written notification from Region 4 ESC. It is the Contractor's responsibility to keep all pricing up to date and on file with Region 4 ESC. All price changes must be provided to Region 4 ESC, using the same format as was provided and accepted in the Contractor's proposal.

Price reductions may be offered at any time during Contract. Special, time-limited reductions are permissible under the following conditions: 1) reduction is available to all users equally; 2) reduction is for a specific period, normally not less than thirty (30) days; and 3) original price is not exceeded after the time-limit. Contractor shall offer Region 4 ESC any published price reduction during the Contract term.

- 18) Audit Rights. Contractor shall, at its sole expense, maintain appropriate due diligence of all purchases made by Region 4 ESC and any entity that utilizes this Contract. Region 4 ESC reserves the right to audit the accounting for a period of three (3) years from the time such

purchases are made. This audit right shall survive termination of this Agreement for a period of one (1) year from the effective date of termination. Region 4 ESC shall have the authority to conduct random audits of Contractor's pricing at Region 4 ESC's sole cost and expense. Notwithstanding the foregoing, in the event that Region 4 ESC is made aware of any pricing being offered that is materially inconsistent with the pricing under this agreement, Region 4 ESC shall have the ability to conduct an extensive audit of Contractor's pricing at Contractor's sole cost and expense. Region 4 ESC may conduct the audit internally or may engage a third-party auditing firm. In the event of an audit, the requested materials shall be provided in the format and at the location designated by Region 4 ESC.

- 19) Discontinued Products. If a product or model is discontinued by the manufacturer, Contractor may substitute a new product or model if the replacement product meets or exceeds the specifications and performance of the discontinued model and if the discount is the same or greater than the discontinued model.
- 20) New Products/Services. New products and/or services that meet the scope of work may be added to the Contract. Pricing shall be equivalent to the percentage discount for other products. Contractor may replace or add product lines if the line is replacing or supplementing products, is equal or superior to the original products, is discounted similarly or greater than the original discount, and if the products meet the requirements of the Contract. No products and/or services may be added to avoid competitive procurement requirements. Region 4 ESC may require additions to be submitted with documentation from Members demonstrating an interest in, or a potential requirement for, the new product or service. Region 4 ESC may reject any additions without cause.
- 21) Options. Optional equipment for products under Contract may be added to the Contract at the time they become available under the following conditions: 1) the option is priced at a discount similar to other options; 2) the option is an enhancement to the unit that improves performance or reliability.
- 22) Warranty Conditions. All supplies, equipment and services shall include manufacturer's minimum standard warranty and one (1) year labor warranty unless otherwise agreed to in writing.
- 23) Site Cleanup. Contractor shall clean up and remove all debris and rubbish resulting from their work as required or directed. Upon completion of the work, the premises shall be left in good repair and an orderly, neat, clean, safe and unobstructed condition.
- 24) Site Preparation. Contractor shall not begin a project for which the site has not been prepared, unless Contractor does the preparation work at no cost, or until Region 4 ESC includes the cost of site preparation in a purchase order. Site preparation includes, but is not limited to: moving furniture, installing wiring for networks or power, and similar pre-installation requirements.
- 25) Registered Sex Offender Restrictions. For work to be performed at schools, Contractor agrees no employee or employee of a subcontractor who has been adjudicated to be a registered sex offender will perform work at any time when students are or are reasonably expected to be present. Contractor agrees a violation of this condition shall be considered a material breach and may result in the cancellation of the purchase order at Region 4 ESC's discretion. Contractor must identify any additional costs associated with compliance of this

term. If no costs are specified, compliance with this term will be provided at no additional charge.

- 26) Safety measures. Contractor shall take all reasonable precautions for the safety of employees on the worksite and shall erect and properly maintain all necessary safeguards for protection of workers and the public. Contractor shall post warning signs against all hazards created by its operation and work in progress. Proper precautions shall be taken pursuant to state law and standard practices to protect workers, general public and existing structures from injury or damage.
- 27) Smoking. Persons working under the Contract shall adhere to local smoking policies. Smoking will only be permitted in posted areas or off premises.
- 28) Stored materials. Upon prior written agreement between the Contractor and Region 4 ESC, payment may be made for materials not incorporated in the work but delivered and suitably stored at the site or some other location, for installation at a later date. An inventory of the stored materials must be provided to Region 4 ESC prior to payment. Such materials must be stored and protected in a secure location and be insured for their full value by the Contractor against loss and damage. Contractor agrees to provide proof of coverage and additionally insured upon request. Additionally, if stored offsite, the materials must also be clearly identified as property of Region 4 ESC and be separated from other materials. Region 4 ESC must be allowed reasonable opportunity to inspect and take inventory of stored materials, on or offsite, as necessary. Until final acceptance by Region 4 ESC, it shall be the Contractor's responsibility to protect all materials and equipment. Contractor warrants and guarantees that title for all work, materials and equipment shall pass to Region 4 ESC upon final acceptance.
- 29) Funding Out Clause. A Contract for the acquisition, including lease, of real or personal property is a commitment of Region 4 ESC's current revenue only. Region 4 ESC retains the right to terminate the Contract at the expiration of each budget period during the term of the Contract and is conditioned on a best effort attempt by Region 4 ESC to obtain appropriate funds for payment of the contract.
- 30) Indemnity. Contractor shall protect, indemnify, and hold harmless both Region 4 ESC and its administrators, employees and agents against all claims, damages, losses and expenses arising out of or resulting from the actions of the Contractor, Contractor employees or subcontractors in the preparation of the solicitation and the later execution of the Contract. Any litigation involving either Region 4 ESC, its administrators and employees and agents will be in Harris County, Texas.
- 31) Marketing. Contractor agrees to allow Region 4 ESC to use their name and logo within website, marketing materials and advertisement. Any use of Region 4 ESC name and logo or any form of publicity, inclusive of press releases, regarding this Contract by Contractor must have prior approval from Region 4 ESC.
- 32) Certificates of Insurance. Certificates of insurance shall be delivered to the Region 4 ESC prior to commencement of work. The Contractor shall give Region 4 ESC a minimum of ten (10) days' notice prior to any modifications or cancellation of policies. The Contractor shall require all subcontractors performing any work to maintain coverage as specified.
- 33) Legal Obligations. It is Contractor's responsibility to be aware of and comply with all local, state, and federal laws governing the sale of products/services and shall comply with all laws

while fulfilling the Contract. Applicable laws and regulation must be followed even if not specifically identified herein.

OFFER AND CONTRACT SIGNATURE FORM

The undersigned hereby offers and, if awarded, agrees to furnish goods and/or services in strict compliance with the terms, specifications and conditions at the prices proposed within response unless noted in writing.

Company Name TSG Industries
Address 7040 Rook Blvd.
City/State/Zip Houston, Texas 77087
Telephone No. 1-888-586-2703
Email Address tsims@tsg-industries.com
Printed Name Theodore Sims
Title Project Executive
Authorized signature 

Accepted by Region 4 ESC:

Contract No. R210502

Initial Contract Term 10/1/2021 to 9/30/2024

 6/29/2021
Region 4 ESC Authorized Board Member Date

Margaret S. Bass

Print Name

 6/29/2021
Region 4 ESC Authorized Board Member Date

Linda Tinnerman

Print Name



7145 West Tidwell Road ~ Houston, Texas
77092 (713)-462-7708

www.esc4.net

NOTICE TO OFFEROR

ADDENDUM NO. 6

Solicitation Number 21-05

Request for Proposal (“RFP”)
by Region 4 Education Service Center (“ESC”)
for Modular Buildings, Portable Storage, and Relocatable Walkways

This Addendum No. 6 amends the Request for Proposal (RFP) for Modular Buildings, Portable Storage, and Relocatable Walkways 21-05 (“Addendum”). To the extent of any discrepancy between the original RFP and this Addendum, this Addendum shall prevail.

Region 4 Education Service Center (“Region 4 ESC”) requests proposals from qualified suppliers with the intent to enter into a Contract for Modular Buildings, Portable Storage, and Relocatable Walkways. Addendum 6 is hereby issued as follows:

CLARIFICATIONS

1. Due to the extreme weather conditions, the Submittal Deadline is being extended via Addendum.
2. Region 4 ESC keeps proposals locked which means proposals are not able to be checked to confirm receipt. As Region 4 ESC wants to ensure proper competition and that all proposals are received by the due date and time, Offeror(s) that chose to submit via mail should keep delivery receipts and confirmations from carriers.
3. Should there be any concerns, Offerors should confirm that they submitted proposals to the correct delivery address with proper labeling as indicated in the RFP.
 - a. Per paragraph 2 (page 1) of the RFP, submissions must be received by the Region 4 ESC office at: 7145 West Tidwell Road, Houston, TX 77092. Offerors may also put to the attention of Crystal Wallace to help ensure receipt. See the RFP for more details.
 - b. Per item 12 of Section III. Instruction to Offerors (page 9) of the RFP,

packages must be clearly identified, sealed and delivered to the Region 4 ESC office. Packages are to include who it is from, the company, the address, solicitation name and number, and due date and time. See the RFP for more details.

4. If Offerors wish to help ensure their proposals were received, they may reach out to questions@esc4.net after 2:00 PM Central Time on Tuesday, March 30, 2021. A response may not be provided, but e-mails will be read. However, it is imperative that Offerors are sending proposals to the correct address and labeled accordingly as if they are sent to an alternate location, they are at risk of having their proposals not accepted.
5. For Offerors that have already submitted a proposal, Acknowledgements of Addendum No. 6 (and as previously stated in a clarification Acknowledgement of Addendum No. 5), do not need to be included with an Offerors response. Region 4 ESC will request Addendum No. 5 and 6 acknowledgements from Offerors who have submitted. When requested by Region 4 ESC, Addendum No. 5 and 6 acknowledgements may be sent via e-mail.
6. For Offerors that have already submitted a proposal, the due date on the package label does not need to be changed.
7. As the Submittal Deadline is being further extended, the Approval from Region 4 ESC and Contract Effective Dates are also being changed via this Addendum.

CHANGES TO THE RFP

1. Page 1, Line 12:

Remove the submittal deadline and replace with the following:

SUBMITTAL DEADLINE: *Tuesday **March 30**, 2021, 2:00 PM CENTRAL TIME*

2. Page 5, Section II. CALENDER OF EVENTS (ALL DATES ARE TENTATIVE AND SUBJECT TO CHANGE):

Remove the calendar of events and replace with the following:

<i>Event</i>	<i>Date</i>
<i>Issue RFP</i>	<i>December 3, 2020</i>
<i>Pre-proposal Conference</i>	<i>December 17, 2020</i>
<i>Deadline for receipt of questions via email</i>	<i>December 18, 2020</i>
<i>Issue Addenda (if required)</i>	<i>January 7, 2021</i>
<i>Proposal Due Date</i>	<i>March 30, 2021</i>
<i>Approval from Region 4 ESC</i>	<i>June 29, 2021</i>
<i>Contract Effective Date</i>	<i>August 1, 2021</i>

All other items on this page shall remain.

RECEIPT OF ADDENDUM NO. 6 ACKNOWLEDGEMENT

Offeror shall acknowledge this addendum by signing below and include in their

Modular Buildings, Portable Storage, and Relocatable Walkways
Solicitation Number 21-05
Addendum No. 6

proposal response.

Company Name TSG Industries

Contact Person Theodore Sims

Signature  _____

Date February 25, 2021

Crystal Wallace
Region 4 Education Service
Center Business Operations
Specialist



7145 West Tidwell Road ~ Houston, Texas 77092

(713)-462-7708

www.esc4.net

NOTICE TO OFFEROR

ADDENDUM NO. 5

Solicitation Number 21-05

Request for Proposal (“RFP”)
by Region 4 Education Service Center (“ESC”)
for Modular Buildings, Portable Storage, and Relocatable Walkways

This Addendum No. 5 amends the Request for Proposal (RFP) for Modular Buildings, Portable Storage, and Relocatable Walkways 21-05 (“Addendum”). To the extent of any discrepancy between the original RFP and this Addendum, this Addendum shall prevail.

Region 4 Education Service Center (“Region 4 ESC”) requests proposals from qualified suppliers with the intent to enter into a Contract for Modular Buildings, Portable Storage, and Relocatable Walkways. Addendum No. 5 is hereby issued as follows:

CLARIFICATIONS

1. The Submittal Deadline is extended via this Addendum.

CHANGES TO THE RFP

1. Page 1, Line 12:

Remove the submittal deadline and replace with the following:

*SUBMITTAL DEADLINE: **Tuesday March 2, 2021, 10:00 AM CENTRAL TIME***

2. Page 5, Section II. CALENDER OF EVENTS (ALL DATES ARE TENTATIVE AND SUBJECT TO CHANGE):

Remove the calendar of events and replace with the following:

<u>Event</u>	<u>Date</u>
<i>Issue RFP</i>	<i>December 3, 2020</i>
<i>Pre-proposal Conference</i>	<i>December 17, 2020</i>
<i>Deadline for receipt of questions via email</i>	<i>December 18, 2020</i>
<i>Issue Addenda (if required)</i>	<i>January 7, 2021</i>
<i>Proposal Due Date</i>	<i>March 2, 2021</i>
<i>Approval from Region 4 ESC</i>	<i>April 27, 2021</i>
<i>Contract Effective Date</i>	<i>July 1, 2021</i>

All other items on this page shall remain.

RECEIPT OF ADDENDUM NO. 5 ACKNOWLEDGEMENT

Offeror shall acknowledge this addendum by signing below and include in their proposal response.

Company Name TSG Industries

Contact Person Theodore Sims

Signature  _____

Date February 23, 2021

Crystal Wallace
Region 4 Education Service Center
Business Operations Specialist



February 22, 2021

Dear Evaluators,

TSG Industries (TSG) is pleased to submit our complete proposal for Modular Buildings, Portable Storage, and Relocatable Walkways with Region 4 ESC/Omni Partners for work specified in the Request for Proposal. We are confident our services offer a comprehensive approach and best value. We stand by our proposal for a period of (3) month and designate a local Project Manager for this project. Our scope of services for **NAICS CODE: 236220** Commercial & Institutional Construction. Our team has an average of 30 years' experience in the industry. The leaders of TSG have helped both public and private institutions build solutions across the nation. See the key aspects that separate us from your typical:

- **Past Experience:** TSG are experienced leaders in modular project services. We have successfully planned, managed and developed more than 2 million square feet in the last 5 years. The Clients family will benefit directly from the depth of our successful past performance.
- **Financial Ability:** TSG maintains a financial sound financial status. TSG is an employee owned company. We are ready to commit all required resources to perform quality services. Our financial record is concise and attests to the accountable and dependable way we do business.
- **Work Plan:** Our approach starts with knowledge of the complete cycle of requirements, Clients will encounter before, during and after the project(s) are complete. Our approach to developing a Project Management Plan is Client-driven for optimal solutions.
- **Project Staffing:** Our Houston-based firm is available for project response and easy access. The modular management team consists of professionals with construction, architecture, and business operation experience. We look to hire locally where training programs will assist with proper placement opportunities. All staff members included in this statement of qualifications will be available.
- **Outreach Plan:** We have a great track record with utilizing local, minority, woman owned businesses as required by our clients. Our outreach objectives include working with local and minority vendors associations. We are supporters of organizations like the Center for JOC Excellence, Texas Society of Military Engineers, Texas Association of School Boards, Texas Association of School Administrators, National Minority Supplier Development Council, City of Houston Affirmative Action, American Water Works Association and Construction Management Association of America.

We look forward to serve as your Modular Systems Representative for this important endeavor.

Sincerely,

A handwritten signature in black ink, appearing to read 'Ted Sims'.

Theodore "Ted" Sims LEED AP, General Manager



BUILDING CAPITAL SOLUTIONS

GENERAL ORGANIZATION

TSG Industries is a Houston based planning and construction service company that manages the successful execution of construction projects including Construction Project Management, General Contracting, Design-Build, Tenant Build-Out and Maintenance Programs for public and private asset portfolios. Also, we offer Prefabricated Modular Structures for special projects including Security, Workspaces and Health Industries. Our leaders have helped federal, public and private institutions build solutions across the nation. The primary scope of service classification is NAICS CODE: 236220 commercial and institutional construction services.

CERTIFICATIONS

- State of Texas Historically Underutilized Business (HUB) Program - Certification# RG019054
- Disadvantage Business Enterprise - Certification# 14-08-12385
- Small Business Enterprise – Certification# 14-8-12385S
- Minority Business Enterprise – Certification# 14-8-12385
- Texas Department of Insurance – Inspector – License# 1822781
- Port of Houston Authority, S/MBE
- South Central Texas Regional Certification Agency – S/M/E/AA/Business Enterprise

AREA OF EXPERTISE

- General Contracting
- Modular & Prefabricated Building Construction
- Construction Manager Agent
- Design-Build
- Workforce Training & Development



BUILDING CAPITAL SOLUTIONS

2200 North Loop West, Ste. 102

Houston, TX 77018

Phone (888)586-2703 Fax (281)605-5037

www.tsg-industries.com



BUILDING CAPITAL SOLUTIONS

REGISTERED COOPERATIVES



AWARDED VENDOR



- TIPS-USA Purchasing Cooperative 200902 Permanent Modular Buildings JOC
- Region 5 ESC 9-2020: IDIQ Portable Buildings, Ramping, Supplies and/or Services #20200903
- Good Buy Cooperative: #18-18 7N000 Facility Services Building/Equipment Maintenance/Repair
- Houston-Galveston Area Council: Modular Buildings MB11-20
- Sourcewell: IDIQ General Contracting TX-GC-GC-021920
- Sourcewell: IDIQ Flooring TX-GC-F-021920
- Aruba Supplier – Renewable Energy Solutions
- Bonfire Supplier

BUSINESS ORGANIZATION

State of Texas: Limited Liability Company – October 4, 2007

Corporate Address:

2200 North Loop West, Ste. 102
Houston, Texas 77018

FEDERAL TAX ID NUMBER:

47-1135838

D-U-N-S NUMBER:

078679713

NAICS CODE:

236220, 332311

SIC CODE:

87420402

CAGE NUMBER:

6TTS6

Office: (888) 586-2703
Fax: (281) 605-5037
Email: tsims@tsg-industries.com
Website: www.tsg-industries.com



BUILDING CAPITAL SOLUTIONS

2200 North Loop West, Ste. 102

Houston, TX 77018

Phone (888)586-2703 Fax (281)605-5037

www.tsg-industries.com



BUILDING CAPITAL SOLUTIONS

PRINCIPAL CONTACTS

Theodore "Ted" Sims
Phone: (832) 660-5914

tsims@tsg-industries.com

Managing Principal

CODES

NIGP Codes:

155-10 Buildings and Structures: Fabricated and Prefabricated
909-11 Airport Maintenance and Repair
909-17 Athletic Facility Maintenance and Repair
909-22 Building Construction, Non-Residential
909-24 Building Construction, Commercial and Institutional
909-57 Land Development and Sub-Division Services
909-63 Maintenance and Repair, Commercial and Institutional Building
910-52 Maintenance and Repair Services, Building
910-63 Public Utilities: Water, Sewer and Gas Maintenance Repair
910-66 Roofing, Gutters and Downspouts Maintenance Repair
912-16 Boring, Drilling, Testing and Soundings
913-36 Construction, Parking Lot and Alley
913-45 Construction, Sewer and Storm Drain
913-47 Construction, Sidewalk and Driveway
988-63 Park Area Construction/Renovation

NAICS Codes:

236220 Commercial and Institutional Building Construction
237110 Water and Sewer Line and Related Structures
238210 Electrical Contractors and Other Wiring Installation Contractors
238220 Plumbing, Heating, and Air-Conditioning Contractors
238910 Site Preparation Contractors
332311 Prefabricated Metal Building and Component Manufacturing

PSC Codes:



BUILDING CAPITAL SOLUTIONS

2200 North Loop West, Ste. 102

Houston, TX 77018

Phone (888)586-2703 Fax (281)605-5037

www.tsg-industries.com



BUILDING CAPITAL SOLUTIONS

5410 Prefabricated and Portable Buildings
Y100 Construction of Structures and Facilities
Z200 Repair or Alteration of Structures and Facilities

UNSPSC Codes:

Prefabricate Structures

30200000 Prefabricated structures
72153100 Athletic and Recreational Facility Construction Services
41104202 Laboratory, Measuring, Observing, and Testing Equipment
48102106 Storage and Handling Equipment and Supplies
421916 Medical Facility Building Systems
26111607 Power Generation and Distribution Machinery and Accessories

Renewable Energy

72120000 Nonresidential Building Construction Services
72151203 HVAC Solar Energy Construction Service
72153700 Parking Maintenance and Repair Service
72141129 Park and Garden Construction and or Remodeling Service

Public Buildings

72121402 Specialized Public Building Construction Services
86101711 Non-Scientific Vocational Training Services

Water Resources

701716 Water Resources Development and Oversight
70171501 Water resources development and oversight
83101502 Public Utilities and Public Sector Related Services

Development Services

81101513 Engineering Design, Research, and Technology Based Services
801016 Project Management Advisory Services
861018 Scientific Vocational Training Services
84101604 Development Finance



BUILDING CAPITAL SOLUTIONS

**2200 North Loop West, Ste. 102
Houston, TX 77018**

Phone (888)586-2703 Fax (281)605-5037

www.tsg-industries.com

MASTER EQUIPMENT LEASE AGREEMENT

This Master Equipment Lease Service Agreement ('Master Agreement') is made this ____ day of _____, 2020 ('Effective Date') by and between TSG Industries, LLC, a Texas limited liability company with its headquarters at 7040 Rook Blvd., Houston, TX 77087, and its successors and assigns ('Lessor') and _____, a _____ with a primary mailing address at _____ ('Lessee').

From time to time Lessee may propose to lease and Lessor may elect to lease to Lessee, various classrooms, trailers and/or relocatable, modular and/or pre-fabricated structures including various appurtenances, such as stairs, railings, furniture, kitchen equipment, security systems and the like (collectively referred to as the 'Equipment'), pursuant to the following covenants.

Lessor and Lessee, intending to be legally bound, mutually agree that all Equipment leased by Lessee from Lessor after the Effective Date hereof shall be subject to the terms and conditions set forth by (i) this Master Agreement; (ii) the General Terms and Conditions; and (iii) the applicable equipment schedule ('Equipment Schedule') issued in conjunction with the subject lease transaction. The Master Agreement, the General Terms and Conditions and each Equipment Schedule shall be collectively referred to as the 'Agreement.'

By its signature below, Lessee acknowledges that it has read the General Terms and Conditions dated January 1, 2020 in their entirety, which are incorporated herein by reference, and agrees to be bound by the terms therein and this Master Agreement. Each party is hereby authorized to accept and rely upon facsimile signature or electronic signature of the other party to this Agreement. Any such signature shall be treated as an original signature for all purposes and shall be fully binding. The undersigned represent that they have the express authority of the respective party they represent to enter into and execute this Agreement and bind the respective party thereby.

1. EQUIPMENT SCHEDULE. An Equipment Schedule for each addition to the Equipment covered under this Agreement will be prepared as the subject Equipment is leased by Lessee from Lessor. The Equipment Schedule will provide the particulars with reference to the Identification and/or Description of the Equipment, a Delivery Date for the Equipment, the Equipment Value, Minimum Lease Term, Periodic Rental Rate and any other necessary specifics. All equipment delivered to Lessee or at Lessee's direction and scheduled on an Equipment Schedule is subject to the terms and conditions of this Agreement. Lessee shall have the right to sub-lease the Equipment upon prior written consent from Lessor.

2. MODIFICATION OF TERMS AND CONDITIONS. The above referenced General Terms and Conditions remain unmodified, and in full force and effect, except to the extent expressly set forth by this Agreement. See the exhibits below:

Exhibit 1 – City of Prairie View, Terms & Supplemental Conditions

Exhibit 2 – Payment & Performance Bonds, if accepted

Exhibit 3 – Work Proposal, if accepted

Exhibit 4 – Project Schedule, if accepted

Accepted By:

Lessee

Lessor

TSG Industries, LLC

(signature)

(signature)

(name and title)

(name and title)

Dated: _____, 2020

Dated: _____, 2020

GENERAL TERMS AND CONDITIONS

1. True Lease. This Agreement is a true lease and not a sale. Lessee shall not acquire ownership interest in the Equipment. The Equipment shall remain the sole personal property of Lessor even though the Equipment may become affixed to, embedded in, or be permanently resting upon real property.

2. Delivery; Acceptance. Upon delivery, Lessee agrees to inspect and accept the Equipment. Lessee shall have forty-eight (48) hours from the date of delivery to notify the Lessor, in writing, of any defects or deficiencies in the Equipment, such notice to specify each defect or deficiency in the Equipment. Unless Lessor receives timely written notice from Lessee as set forth herein, Lessee is deemed to accept the Equipment and acknowledges that the Equipment is in good order and operating condition as of the date of delivery. The receipt and acceptance of the Equipment by Lessee obligates Lessee to pay the Rental and all other sums due under this Agreement.

3. Term of Lease; Extension. The term of this Agreement begins on the date of delivery of the Equipment, and ends on the last day of the Minimum Lease Term ('Term') or the Extension Period (as herein defined).

At the end of the Term, this Agreement is extended on a month-to-month basis until the Equipment is returned to Lessor (the 'Extension Period'). During the Extension Period, Lessor has the right to, on thirty (30) days notice, increase the Rate Per Month and/or the dismantle and return freight charges to Lessor's then prevailing rate. After the end of the Term, either party can terminate this Agreement on thirty (30) days written notice. Lessee shall have no right to cancel or terminate this Agreement during the Term.

4. Site Suitability; Inspection. Lessee shall choose a firm level site accessible by truck to locate the Equipment. Lessee shall own such site and/or have express legal authorization to locate the Equipment upon that same site. If Lessee fails to provide such a site, then Lessee shall pay for any resulting additional delivery, installation, and knock down and return charges, including, but not limited to, storage related charges attributable to delayed delivery and/or installation of the Equipment required and/or requested by Lessee. Lessee shall not alter the manner of installation or location of the Equipment without written consent of Lessor. Lessor shall have the right to enter the premises and inspect the Equipment normal business hours during the term of this Agreement and any Extension Period. Lessor does not recommend or support the stacking of Equipment. Do not stack Equipment unless you have the approval of qualified engineering professionals, comply with all occupational safety laws, and obtain all zoning, building, and occupancy permits. Notwithstanding any express terms to the contrary, Lessor disclaims all warranties, express or implied, if the Lessee stacks Equipment.

5. Use; Maintenance; Condition. Lessee has the right to peaceably and quietly hold, use and enjoy the Equipment, subject to the terms and conditions of this Agreement. Lessee shall use the equipment solely in the conduct of its business and in a careful and lawful manner. Lessee agrees not to remove existing nameplates or decals affixed to the Equipment. Lessee shall pay any and all fees, charges and expenses and comply with all laws related to the use, possession, and operation of the Equipment while it is in Lessee's possession, including obtaining all approvals and permits related to the use and/or possession of the Equipment. Lessee shall maintain and keep the Equipment in good repair and safe operating condition during the term of this Agreement. Lessee shall keep the Equipment properly ventilated and shall not allow, or permit any condition to exist that allows standing water to accumulate in, on or under the Equipment. Lessee shall not, without Lessor's prior written consent, make any changes, alterations or improvements in or to the Equipment or remove any parts, accessories or attachments therefrom. Lessee assumes full responsibility for any stairs, railings, furniture, accessories, attachments or other items missing from the Equipment upon return. If Lessee should require Equipment that meets certain local codes and/or ordinances, Lessee shall notify Lessor at the time Equipment is ordered. Any special requirements shall be handled on a case-by-case basis. Lessor makes no representations as to the Equipment's compliance with federal, state or local building codes, zoning ordinances, or other types of regulations or codes.

6. Hazardous Materials. Lessee shall not use, release, store, dispose of, or otherwise have present any Hazardous Materials in, on, under or near the Equipment, unless Lessor shall have first consented in writing to such use or presence of Hazardous Materials, and such Hazardous Materials are used, stored, manufactured, disposed of or otherwise present in accordance with all applicable laws. 'Hazardous Materials' shall mean any explosives, flammable substances, radioactive materials, asbestos, paints containing lead, materials containing urea, formaldehyde, polychlorinated biphenyls, oil, petroleum byproducts, or any other hazardous, toxic, dangerous or otherwise regulated substances, wastes, pollutants, contaminants, or biological substances (including fungi, bacteria, mold and microbial matter of any kind) whether having such characteristics in fact or defined as such under federal, state or local laws and regulations.

7. Rent; Fees; Taxes; Late Charges. Rent begins to accrue upon completion of delivery and set-up of the equipment (the 'Delivery Date'). Lessee shall pay Lessor, in advance, monthly rent for the Equipment on the due date at the Rate Per Month stated in this Agreement during the Term, and at the Rate Per Month established by Lessor during the Extension Period. If any payment is not paid on the due date, Lessee agrees to pay Lessor a charge of 1.5% or maximum amount permitted by law, per month of the amount in arrears for the period such amount remains unpaid. Lessee shall pay or, if requested by Lessor, reimburse Lessor for any and all sales, use, personal property taxes, or other taxes, fees or assessments levied against or imposed upon the Equipment, its value, use or operation or levied against or based upon the rentals paid or to be paid hereunder. Payments shall be effective upon receipt. Lessor may apply any payment from Lessee against obligation due and owing by Lessee under this Agreement, regardless of any statement appearing on or referred to in any remittance from Lessee or any prior application of payment. The receipt by Lessor of a partial payment of any amount due to Lessor endorsed as payment in full will be deemed to be a part payment only, and any endorsements or statements on the check or any letter accompanying the check shall not be deemed an accord and/or satisfaction, and notwithstanding said endorsements, Lessor may accept and deposit said check without prejudice to its right to recover the balance. Lessee's obligation (without prior notice or demand) to pay rent and all other amounts due hereunder shall be absolute and unconditional, and not be subject to any abatement, set off, defense, recoupment, or reduction for any reason whatsoever.

8. No Liens. Lessee, at its sole cost and expense, agrees to keep the Equipment free and clear of any and all claims, liens, security interests, encumbrances or attachments not arising out of Lessor's acts including, without limitation, mechanics' and materialman's liens.

9. Indemnity. Lessee agrees to indemnify, defend and keep harmless Lessor, its parents, subsidiaries, affiliates, directors, officers, agents, employees, and invitees, from and against any and all losses, claims, costs and attorney's fees and expenses, including but not limited to those arising out of or caused by the negligence of Lessor or its agents or employees, arising out of or related to: (a) any loss or damage to the Equipment or any part or component thereof; (b) the death of, injury to, or damage to the property of, any person or party related to or arising out of the delivery, installation, use, possession, condition, return or repossession or relocation (by other than Lessor's employees and/or subcontractors) of the Equipment and any part or component thereof; and/or (c) failure of Lessee to maintain the Equipment as agreed to herein. Lessee shall give Lessor immediate notice of any claim or liability hereby indemnified against.

10. Loss; Damage. Lessee assumes the risk of all loss and damage to the Equipment from all causes, including loss of use. Upon the occurrence of the total loss of the Equipment, to such an extent as to make the repair thereof uneconomical (in Lessor's sole opinion) Lessor shall declare the Equipment a Total Loss. In the event of a Total Loss, Lessee shall pay Lessor, on the next date for the payment of rent, the rent then due plus the value of the Equipment (the 'Equipment Value') as stipulated in the Agreement plus the value of all accessories less all insurance proceeds actually paid and/or assigned to Lessor from insurance maintained by Lessee, plus all applicable sales and/or transfer taxes (the 'Total Loss Amount'). Upon Lessor's receipt of the Total Loss Amount, the Lessee's lease obligation will terminate. Lessor will transfer available documents of ownership of the Equipment to Lessee unless Lessor agrees to dispose of the Equipment at Lessee's cost and expense. In the event of loss or damage to the Equipment that does not constitute a Total Loss, Lessee at its sole cost and expense, shall pay or reimburse Lessor, to the extent Lessor has not been paid or reimbursed from insurance maintained by Lessee, for the repair of such damage as directed by Lessor to the condition required by this Agreement. Any loss or damage to the Equipment shall not reduce or otherwise abate Lessee's obligation to pay all rental payments when due. Lessee's obligation to pay Lessor amounts pursuant to this Section 10 shall be binding upon Lessee in accordance with the terms hereof.

11. Insurance. Lessee's responsibility for the Equipment begins immediately upon delivery. Lessee shall obtain and keep in force during the entire Term and/or Extension Period, liability and property insurance as follows: (A) General Liability Insurance: A policy of combined bodily injury and property damage insurance insuring Lessee and Lessor against any liability arising out of the use, maintenance, or possession of the Equipment. Such insurance shall be in an amount not less than \$1,000,000 per occurrence. (B) Property Insurance: A policy of insurance covering all loss or damage to the Equipment, including flood and earthquake, for not less than 100% of the Equipment Value and accessories, for the full term of the Agreement. (C) General: (1) Lessee's insurance for the Equipment shall be issued by insurance companies satisfactory to Lessor. Such insurance shall be primary, and any other coverage carried by the Lessor shall be excess and non-contributory. Within ten (10) days after the delivery of the Equipment, Lessee shall provide Lessor with evidence of the required insurance and naming Lessor as Additional Insured and Loss Payee. The evidence of insurance must provide Lessor with thirty (30) days prior written notice of any cancellation. Any proceeds of such insurance shall be paid to Lessor and shall be applied to the replacement of the Equipment or payment of monies under this Agreement, at the option of the Lessor. Lessee shall comply with all requirements of the insurance underwriters or any governmental authority. (2) Lessee shall pay a Missing or Expired Evidence fee for each month that Lessee fails to timely provide the required Evidence of Insurance for property coverage or for liability coverage. Such fees shall be calculated by Lessor at its then prevailing rate(s). Payment of such fees shall not provide Lessee with any insurance coverage, nor excuse Lessee from performing its obligations under Sections 9 and 10.

12. Defaults; Remedies. (A) Lessee shall be deemed to be in default hereunder upon the occurrence of any of the following events ('Events of Default'): (1) Lessee shall fail to make any payment due hereunder within ten (10) days after its due date; (2) Lessee shall fail to perform or observe any other term, covenant,

or condition of this Agreement; (3) Lessee shall have abandoned the Equipment; (4) any representation or warranty of Lessee shall have been untrue in any material respect when made, or any information submitted by Lessee to Lessor shall be false or misleading in any material respect; or (5) Lessee shall have defaulted under any other agreement with Lessor. (B) Upon the occurrence of an Event of Default, Lessor may declare this Agreement to be in Default, and thereafter may exercise any one or more of the following remedies: (1) declare the rent for the Term and all other unpaid rent, fees, taxes and charges under this Agreement immediately due and payable; (2) Repossess, retake and/or retain any or all of the Equipment free of all rights and claims of Lessee without notice, without legal process, or judicial intervention, and without releasing Lessee of any term, covenant or condition provided herein; (3) Sell or otherwise dispose of any or all of the Equipment, whether or not in Lessor's possession, in a commercially reasonable manner and apply the net proceeds of such disposition, after deducting all costs, to the obligations of Lessee, with Lessee remaining liable for any deficiency; (4) Terminate this Agreement; and/or (5) Exercise any other right or remedy available to Lessor at law or in equity. Lessor's waiver of any Event of Default shall not constitute a waiver of any other Event of Default or a waiver of any term or condition of this Agreement. Lessee shall pay all Lessor's legal fees and all other costs and expenses incurred by reason of any Event of Default. No right or remedy referred to herein is intended to be exclusive, and each may be exercised concurrently or separately and from time to time. In the event Lessor shall repossess or retake the Equipment, and there shall be in or attached to such Equipment any property owned by, or in the custody or control of Lessee, then Lessor is hereby authorized to take possession of such property for a period of ten (10) days. Thereafter, if any such property is not claimed and taken by Lessee within ten (10) days after Lessor repossesses or retakes the Equipment, such property shall be deemed abandoned by Lessee, and Lessor shall have the right to dispose of it. (C) Lessee and Lessor waive all right to trial by jury of all claims, defenses, counterclaims and suits of any kind arising from or relating to this Agreement.

13. Return of Equipment; Termination of Lease. At the end of the Term or any Extension Period, lessee shall make the equipment available to Lessor, without impediment, at the Delivery Address or any other address to which Lessor has previously provided written approval of relocation of the equipment. Any impediment to pick-up of the Equipment may result in additional charges to Lessee. Lessee shall provide Lessor with at least thirty (30) days advance written notice of the return of the Equipment. In the event Lessee does not provide thirty (30) days advance written notice of the return of the Equipment and such earlier pick-up of the Equipment is requested by Lessee (and can be effected by Lessor), Lessee shall reimburse Lessor for any related costs and expenses associated with the immediate pick-up of the Equipment. Lessee acknowledges and agrees that during the Extension Period all amounts for return freight, knockdown and dismantle will be billed by Lessor to Lessee at the rates then in effect on the date of surrender. The Equipment shall be broom clean and in the same condition as delivered to Lessee, ordinary wear and tear excepted. Termination will become effective only when the Equipment has been returned to Lessor as herein provided and Lessee has paid Lessor all unpaid rental and other charges applicable to the Equipment. Lessee agrees that prior to the return of the Equipment to Lessor or upon notice of its repossession; Lessee shall, at its sole cost and expense, immediately disconnect all utilities, remove all of Lessee's personal property, and vacate the Equipment. Lessee hereby consents to entry by Lessor or its agents upon the premises where the equipment may be located for return or repossession of the Equipment. Lessor shall not be responsible for site restoration. Lessor shall not be liable for any damage to any personal property left in or on the Equipment or for keeping or storing any personal property of Lessee left in or on the Equipment; any such property will be deemed abandoned by Lessee. Any accessories and additions to the returned Equipment shall be deemed part of the Equipment and the property of Lessor. Lessee shall reimburse Lessor for any and all costs incurred related to the return of the Equipment and in repairing, cleaning or otherwise restoring the Equipment to its condition when delivered, ordinary wear and tear excepted.

14 Limited Warranty. For as long as Lessee timely makes all payments due hereunder, Lessor warrants throughout the term of this Agreement that it will repair structural or mechanical defects in the Equipment

(excluding HVAC filters, fire extinguishers, fuses/breakers, light bulbs or other ordinary course repairs or maintenance) provided that Lessee notifies Lessor in writing of any defects, malfunctions, or leaks within two (2) business days of the occurrence thereof. In any event, the liability of Lessor shall be limited solely to the repairing of defects in the Equipment. Lessor shall have no liability for the repair of any defect or condition resulting from Lessee's relocation of the Equipment, utilities connection, alteration of the equipment, use of the Equipment for a purpose for which it was not intended, vandalism, misuse of the Equipment, for excessive wear and tear or for which timely notice is not provided to Lessor. The repair of the Equipment by Lessor, due to a defect or condition resulting from any of the preceding causes shall result in additional charges to the Lessee. Lessor shall have no liability whatsoever for any consequential, incidental or punitive damages, costs or expenses. **Except as specifically provided herein, Lessor disclaims any and all warranties, express or implied, related to the Equipment and any maintenance or repair work performed by Lessor including warranties for merchantability, suitability, or fitness for a particular purpose.**

15. Assignment. Lessee shall not assign this Agreement or sublet the Equipment without the prior written consent of Lessor. This Agreement shall be binding upon any permitted assignee or successor of Lessee. Lessor may assign any of its rights and/or obligations hereunder without notice to Lessee.

16. Miscellaneous. (a) Time is of the essence with respect to this Agreement. (b) This Agreement, when signed by both parties, constitutes the entire agreement between the parties, superseding and replacing all prior documents and representations, with respect to the subject matter hereof. It may only be amended by a document signed by both parties. The terms of any documents submitted by Lessee (i) are superseded and replaced in their entirety by the terms and conditions of this Agreement and (ii) shall otherwise have no binding effect upon Lessor, its agents and employees. Acknowledgement by Lessor of any Lessee supplied documents shall be for Lessee's billing purposes only. (c) If any provision of this Agreement is deemed unenforceable for any reason, then such provision shall be deemed stricken and shall not affect the enforceability of any of its other provisions. Notwithstanding anything contained herein to the contrary, if it should be determined by a court of competent jurisdiction that any indemnification or other protection afforded to an indemnitee under Section 9 would be in violation of or otherwise prohibited by any applicable law, then Section 9 shall automatically be deemed to be amended in a manner which provides the maximum indemnification and other protections to such indemnitee consistent with such applicable law. (d) The obligations of Lessee under Sections 7, 8, 9 and 10 which accrue during the term of this Agreement, shall survive the termination of this Agreement. (e) If Lessee fails to perform any of its obligations hereunder, Lessor shall have the right to effect such performance; the amount of any out-of-pocket and other reasonable expenses of Lessor incurred in connection with such performance shall be payable by Lessee upon demand. (f) Lessor shall not be responsible for delays beyond its control. (g) Lessor shall have no liability whatsoever for any consequential, incidental or punitive damages, costs or expenses. (h) Lessee irrevocably appoints Lessor or its agents or assigns as Lessee's attorney-in-fact to execute any UCC financing statements, documents, and checks and drafts related to payment of any loss, damage or defense under policies of insurance required by this Agreement. (i) This Agreement shall in all respects be governed by the laws of the State of Texas regardless of the location of the Equipment. Lessee hereby consents and submits to the jurisdiction of the courts of Harris County, Texas for purposes of enforcement of this Agreement. Lessor hereby reserves its common law right of offset. Lessee hereby waives any and all rights to or claims of sovereign immunity. (j) Lessee will pay all costs and expenses, including reasonable attorney's fees, incurred by Lessor in enforcing any terms, covenants and indemnities provided herein. (k) Each party is hereby authorized to accept and rely upon a facsimile signature or electronic signature of the other party on this Agreement or any amendment thereto. Any such signature shall be treated as an original signature for all purposes. (l) Each party is hereby authorized to accept and rely upon documents in paper or electronic format.

General Terms and Conditions
January 1, 2020

Region 4 Education Service Center

Modular Buildings, Portable Storage, and Relocatable Walkways

Solicitation Number 21-05

TAB 1

Products and Pricing

TSG Modular Building System Applications

Special Item Number: 361

Pre-Engineered and Prefabricated Buildings and Structures for State Institutions, Military and Disaster/Emergency Response



Miscellaneous Adds:

1. Demolition of Existing
2. Set new units and Anchor
3. New Electrical Service
4. New Water Service
5. Security Systems



TSG Modular Building System Applications

Special Item Number: 361

Pre-Engineered and Prefabricated Buildings and Structures for State Institutions, Military and Disaster/Emergency Response

Part Number: 122633 Lawson Academy Price 1: \$68.10/ SF (Full Design-Build)
Price 2: \$58.03/SF (Standard)

Product Name: Prefabricated Modular Building Lease Option Price: N/A

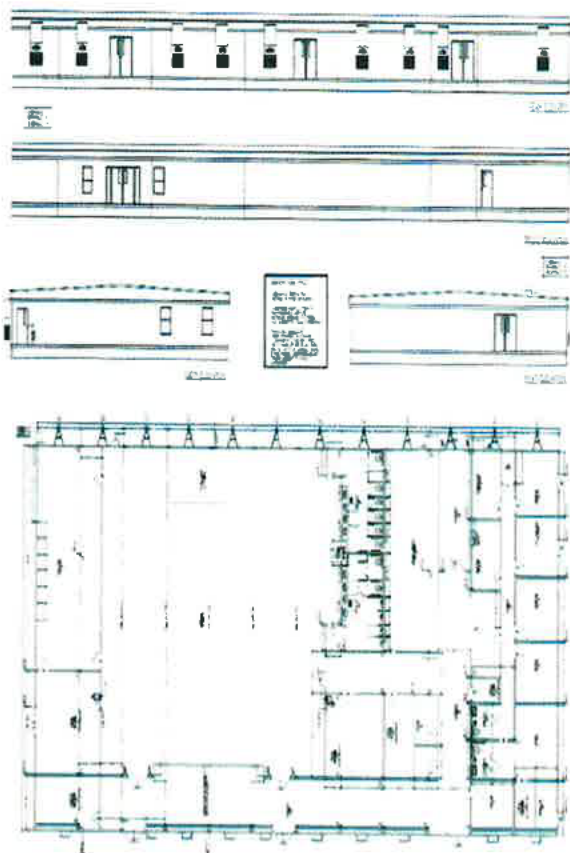

The Lawson Academy has developed a 36,632 sq. ft. middle school which will be comprised of 20 classrooms, 2 science laboratories, administrative offices and class prep space, athletic and recreational spaces.

The campus is comprised in a U-shaped 3 building configuration that total 36,632 square feet. The building configuration consists of a main administrative and assembly space building with two identical classroom buildings aligned at both ends. The administrative building includes an **"Hall of Achievement"**, administrative, nurse, conference, cafetorium and support space. The classroom buildings include a boy's and girl's wing. Each wing includes classrooms, computer lab, science lab, social studies, physical education, intervention, tutoring, arts, music and administrative support space. The wood frame superstructures are set on a combination perimeter CMU and blocking system. The exterior walls are painted insulated R-panel metal exterior walls. The roofing is a black EPDM (synthetic rubber) roof covering. The exterior windows are double pane, Low-E windows for energy efficiency. The exterior doors are commercial grade metal with optimum access control for child safety. The exterior treated wood walkways and canopies are handicap accessible

and have adequate fire separation. The building and site has 19 LED efficient exterior and site lights combined including eleven (11) pole lights and (8) wall mounted lighting packages.

TSG Modular Building System Applications
Special Item Number: 361
Pre-Engineered and Prefabricated Buildings and Structures for State Institutions, Military and
Disaster/Emergency Response

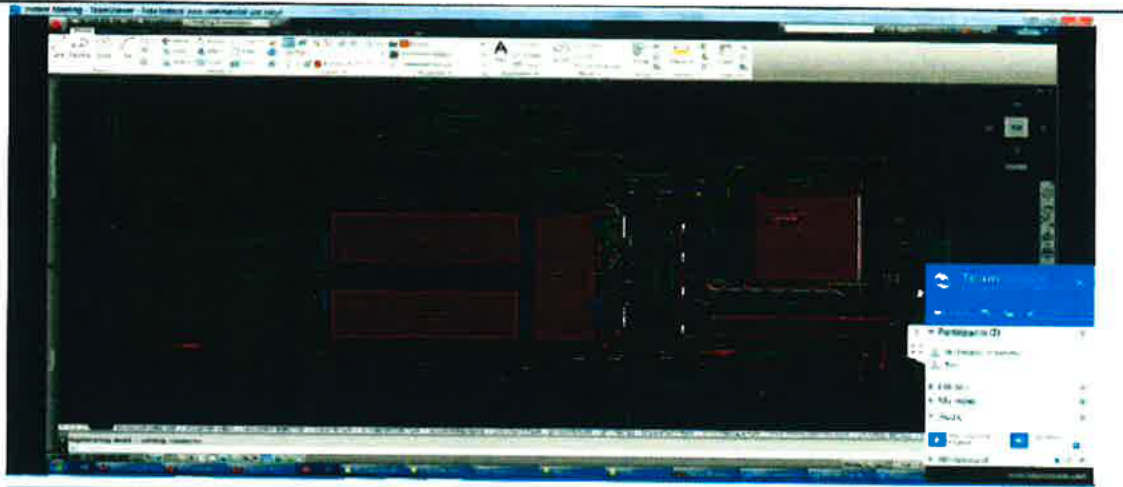

TSG Modular Building System Applications

Special Item Number: 361

Pre-Engineered and Prefabricated Buildings and Structures for State Institutions, Military and Disaster/Emergency Response

Part Number:	121765 Beaumont ISD	Price 1:	\$196.73/ SF (Full Design-Build)
		Price 2:	\$170/SF (Standard)
Product Name:	Prefabricated Modular Building	Lease Option Price:	N/A

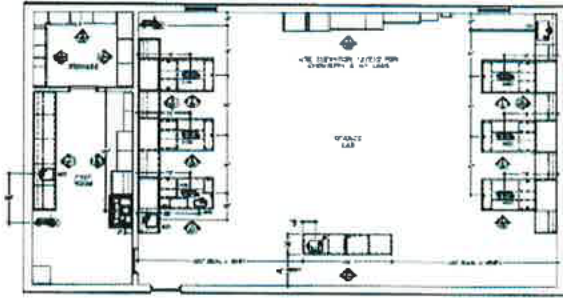

Additions: Homer Drive Elementary School added pre-cast concrete classrooms on the existing campus. The basis for design was predicated on pre-fabricated modular units. The ten additional regular classrooms consisted of approximately 800 sq.ft each., each with necessary access and ancillary space. All modules were designed and built to suit the specific needs of the BISD. 47,621 sf



Marshall Middle School added pre-cast concrete additional classrooms on the existing campus. Two types of classrooms were added: three science classrooms, consisting of 1,200 square feet plus ancillary space and seven regular classrooms consisting of approximately 800 square feet each with necessary access and ancillary space. Buildings of different sizes were provided and adapted to the classroom and science room spaces.; one design can have multiple uses. 11,058 sf



West Brook High School will add fourteen new pre-cast concrete classrooms to the twenty-six classrooms constructed during the first phase of this project, totaling thirty-four new classrooms and six science labs. 11,058 sf



TSG Modular Building System Applications
Special Item Number: 361
Pre-Engineered and Prefabricated Buildings and Structures for State Institutions, Military and
Disaster/Emergency Response

Federal Supply Schedule 056 – BUILDINGS AND BUILDING MATERIAL SERVICES AND SUPPLIES

CONTRACTOR INFORMATION:

Sales

Name: TSG Industries, LLC
Address: 2200 North Loop West, Suite 102
Houston, Texas 77054
Telephone: 713-218-0211
Email: tsg-industries.com
Website: www.tsg-industries.com
Business Type: Certified Small Disadvantage Business

Contract Administrator

Ted Sims, LEED AP
Mobile: 832-660-5914
E-mail: tsims@tsg-industries.com

CUSTOMER NOTES:

1. All building calculations include a 5 foot perimeter around each unit for utility service cut-off.
2. Geographic Coverage: Alabama, Oklahoma, New Mexico, Texas, Louisiana
3. Points of Production: Houston, Texas, Willacoochee, Georgia.
4. Basic Discount: 1.75% discount applied upon typical order. Additional 1% discount to pay within 15 days.
5. Time of delivery: 180 days after ARO. Based on type and quantity of order.
6. Expedited delivery: 150 days after ARO with coordination.
7. Urgent requirements: Agencies can contact the contractors rep to affect a faster delivery.
Customers are encouraged to contact the contractor for the purpose of requesting accelerated delivery.
8. FOB Point: Origin-prepay and add.
9. Ordering Address:
TSG Industries LLC.
2200 North Loop West, Suite 102
Houston, Texas 77054
10. Ordering procedures: Phone, fax, email.
11. Payment Address:
TSG Industries LLC.
2200 North Loop West, Suite 102
Houston, Texas 77054
12. Warranty provisions: Standard commercial warranty. No returns
13. Export packaging charges: N/A
14. System Award Management Registration Database: Yes
15. Data Universal Number System Number: 078679713

TSG Modular Building System Applications
Special Item Number: 361
 Pre-Engineered and Prefabricated Buildings and Structures for State Institutions, Military and
 Disaster/Emergency Response

ALTERNATE PRICING SHEET

SIN	Service	Description	Unit of Measure	Price
361-32	1	Dry-stack CMU Piers	Each	\$ 50.25
361-32	2	Anchors	Each	\$ 55.28
361-32	3	Deck Installation, Galvaloom	SF	\$ 30.13
361-32	4	Skirting Installation	LF	\$ 24.12
361-32	5	Electrical Service	Allowance	\$ 15,000.00
361-32	6	Plumbing Service	Allowance	\$ 10,000.00
361-32	7	Fire Alarm Service	Allowance	\$ 7,500.00
361-32	8	Phone/Data/Security	Allowance	\$ 20,000.00
361-30	9	Site Superintendent (100%)	Per Week	\$ 2,992.95
361-30	10	Engineered Plans (TDLR)	Allowance	\$ 25,000.00
361-30	11	Permitting/Inspections	Allowance	.45% of total cost

Note 1: Above prices do not include reimbursable expenses such as lodging, meals, travel/transportation costs, or incidental expenses.

Note 2: TSG prices include standard site and building clean-up (removal of construction debris, sweeping etc.). Upon customer request a more thorough cleaning to make the facility ready for occupancy may be required.

PRODUCT ITEM BASE OFFERING PRICES								
Offeror Name:	TSG Industries							
	21-05 New / Leased Modular Buildings & Shelters							
NOTES:	New inventory with market adjustment pricing.							
AA. Mobile Modular								
Base Product Code	Description	Sales Price New	Monthly Lease Cost / Term in Months					
			6 to 12	13 to 24	25 to 36	37 to 48	49 to 60	61 plus
HH. TSG Industries								
Base Product Code	Description	Sales Price New	Monthly Lease Cost / Term in Months					
			6 to 12	13 to 24	25 to 36	37 to 48	49 to 60	61 plus
A. Classroom, Educational and Administrative								
MB18HHA01	Double Classroom Modular Building w/Restrooms, 24' x 64'	\$48/per sf	2.26/sf	\$2.21/sf	\$2.16/sf	\$1.47/sf	\$1.47/sf	\$1.47/sf
MB18HHA02	Double Classroom Modular Building w/o Restrooms, 24' x 64'	\$45/per sf	2.21/sf	\$2.18/sf	\$2.14/sf	\$2.11/sf	\$2.11/sf	\$2.11/sf
MB18HHA03	4 - Classroom Modular Building w/Restrooms, 43'-3" x 66"	\$54/per sf	4.54/sf	\$4.31/sf	\$4.19/sf	\$3.97/sf	\$3.97/sf	\$3.97/sf
MB18HHA04	4 - Classroom Modular Building w/o Restrooms, 43'-3" x 66'	\$51/per sf	4.25/sf	\$4.21/sf	\$4.17/sf	\$3.95/sf	\$3.95/sf	\$3.95/sf
MB18HHA05	6 - Classroom Modular Building Wing w/Restrooms, 96'-3" x 64'	\$38/ sf	\$2.68/sf	\$2.63/sf	\$2.58/sf	\$2.54/sf	\$2.54/sf	\$2.54/sf
MB18HHA06	Science Lab	\$48/sf	\$4.05/sf	\$3.93/sf	\$3.86/sf	\$3.79/sf	\$3.79/sf	\$3.79/sf
MB18HHA07	Cafeteria	\$36/sf	\$3.15/sf	\$2.85/sf	\$2.29/sf	\$2.26/sf	\$2.26/sf	\$2.26/sf
MB18HHA08	Administration office	\$46/sf	\$3.85/sf	\$3.05/sf	\$3.01/sf	\$2.95/sf	\$2.95/sf	\$2.95/sf
MB18HHA09	10' x 40' Press Box (steel)	\$109.25/ sf	N/A	N/A	N/A	N/A	N/A	N/A
MB18HHA10	12' x 40' Press Box (steel)	\$115/ sf	N/A	N/A	N/A	N/A	N/A	N/A
MB18HHA11	Guardbooth	\$481/ sf	\$42/sf	\$34/sf	\$26/sf	\$19/sf	\$19/sf	\$19/sf
B. Offices								
MB18HHB01	12X60 DOUBLE OFFICE	\$46/sf	\$1.90/sf	\$1.84/sf	\$1.78/sf	\$1.72/sf	\$1.72/sf	\$1.72/sf
MB18HHB02	14X70 DOUBLE OFFICE	\$44/sf	\$1.85/sf	\$1.79/sf	\$1.73/sf	\$1.95/sf	\$1.95/sf	\$1.95/sf
MB18HHB03	24X60 FOUR OFFICE	\$42.50/sf	\$3.54/sf	\$3.35/sf	\$3.01/sf	\$2.95/sf	\$2.95/sf	\$2.95/sf
MB18HHB04	Four office with restroom, 24' x 56'	\$43.50/sf	\$3.62/sf	\$3.41/sf	\$2.96/sf	\$2.90/sf	\$2.90/sf	\$2.90/sf
MB18HHB05	6 office with conference room, 28' x 69'	\$44/sf	\$1.85/sf	\$1.79/sf	\$1.73/sf	\$1.95/sf	\$1.95/sf	\$1.95/sf
MB18HHB06	8'6" x 20' (2) Office Building (steel)	\$89/sf	N/A	N/A	N/A	N/A	N/A	N/A
MB18HHB07	12' x 20' (2) Office Building (steel)	\$94.50/sf	N/A	N/A	N/A	N/A	N/A	N/A
MB18HHB08	14' x 20' (2) Office Building (steel)	\$95/sf	N/A	N/A	N/A	N/A	N/A	N/A
MB18HHB09	8'6" x 40' (2) Office Building (steel)	\$46/sf	N/A	N/A	N/A	N/A	N/A	N/A
MB18HHB10	12' x 40' (2) Office Building (steel)	\$51.50/sf	N/A	N/A	N/A	N/A	N/A	N/A
MB18HHB11	14' x 40' (2) Office Building (steel)	\$53/sf	N/A	N/A	N/A	N/A	N/A	N/A

Base Product Code	Description	Sales Price New	Monthly Lease Cost / Term in Months					
			6 to 12	13 to 24	25 to 36	37 to 48	49 to 60	61 plus
MB18HHB12	12' x 40' (2) High Cube Office Building (steel)	\$83.50/sf	N/A	N/A	N/A	N/A	N/A	N/A
MB18HHB13	14' x 40' (2) High Cube Office Building (steel)	\$85.25/sf	N/A	N/A	N/A	N/A	N/A	N/A
C. Medical, Health Care								
MB18HHC01	41' x 56' Medical Office Building	\$114/ sf	N/A	N/A	N/A	N/A	N/A	N/A
MB18HHC02	47' x 60' Medical Office Building	\$114/ sf	N/A	N/A	N/A	N/A	N/A	N/A
MB18HHC03	35' x 60' Medical Office Building	\$114/ sf	N/A	N/A	N/A	N/A	N/A	N/A
MB18HHC04	24' x 64' Medical Office Building	\$114/ sf	N/A	N/A	N/A	N/A	N/A	N/A
MB18HHC05	12' x 20' X-Ray Building (steel)	\$707/sf	N/A	N/A	N/A	N/A	N/A	N/A
D. Restrooms and Specialty								
MB18HHD01	24' x 60' Locker / Shower Building (steel)	\$47/sf	N/A	\$2.55/sf	\$2.55/sf	\$2.45/sf	\$2.27/sf	\$2.27/sf
MB18HHD02	Dormitories 4-10	\$58/sf	\$4.15/sf	\$4.15/sf	\$3.98/sf	\$3.98/sf	\$3.25/sf	\$3.25/sf
MB18HHD03	Kitchen 100 Person	\$36/sf	\$3.15/sf	\$2.85/sf	\$2.29/sf	\$2.26/sf	\$2.26/sf	\$2.26/sf
MB18HHD04	Ticket Booth (Steel)	\$182.50/sf	\$6.08/sf	\$6.08/sf	\$6.08/sf	\$5.75/sf	\$5.75/sf	\$5.75/sf
MB18HHD05	Locker Room	\$91/sf	\$5.75/sf	\$5.75/sf	\$5.05/sf	\$4.85/sf	\$4.80/sf	\$4.80/sf
MB18HHD06	8' x 45' Laboratory Building (steel)	\$92.75/sf	N/A	N/A	N/A	N/A	N/A	N/A
MB18HHD07	8'6" x 20' Cleanroom (steel)	\$99/sf	N/A	N/A	N/A	N/A	N/A	N/A
MB18HHD08	Mechanical Room	\$38/sf	N/A	N/A	N/A	N/A	N/A	N/A
MB18HHD09	Blast Proof Storage Building	\$287/sf	N/A	N/A	N/A	N/A	N/A	N/A
MB18HHD10	Pre-Fab Laboratory (concrete)	\$81/sf	N/A	N/A	N/A	N/A	N/A	N/A
MB18HHD11	8'6" x 40' Concession (steel)	\$85/sf	\$5.35/sf	\$5.35/sf	\$5.05/sf	\$5.05/sf	\$4.75/sf	\$4.75/sf
E. Stairs, Ramps, Service Rates and all other Accessories								
MB18HHE01	Ramp & Landing Skirting, Metal (cost per linear foot)	\$ 4,005.00	N/A	N/A	N/A	N/A	N/A	N/A
MB18HHE02	Ramp & Landing Skirting, Wood (cost per linear foot)	\$26.50/lf	N/A	N/A	N/A	N/A	N/A	N/A
MB18HHE03	5' x 5 1/2' Landing w/ up to 30' ADA ramp (alum.)	\$ 3,587.50	N/A	N/A	N/A	N/A	N/A	N/A
MB18HHE04	15' x 5 1/2' Landing w/ up to 30' ADA ramp (alum.)	\$143.50/sf	N/A	N/A	N/A	N/A	N/A	N/A
MB18HHE05	Add 4' wide steps to landing, 21" (alum.)	\$75/ea	N/A	N/A	N/A	N/A	N/A	N/A
MB18HHE06	Add 4' wide steps to landing, 28" (alum.)	\$78/ea	N/A	N/A	N/A	N/A	N/A	N/A
MB18HHE07	Additional Ramp & Landing (inc. rail) cost per sq. ft.	\$65/sf	N/A	N/A	N/A	N/A	N/A	N/A
MB18HHE08	5' x 5' Landing w/ up to 30' ADA ramp (wood)	\$45/sf	N/A	N/A	N/A	N/A	N/A	N/A
MB18HHE09	15' x 10' Landing w/ up to 30' ADA ramp (wood)	\$45/sf	N/A	N/A	N/A	N/A	N/A	N/A
MB18HHE10	Add Ramp Landing (cost per sq. ft.) (wood)	\$45/sf	N/A	N/A	N/A	N/A	N/A	N/A
MB18HHE11	Additional Guardrail (cost per sq. ft.) (wood)	\$27.50/sf	N/A	N/A	N/A	N/A	N/A	N/A
MB18HHE12	Prefabricated metal steps, 3-risers / each	\$ 1,600.00	N/A	N/A	N/A	N/A	N/A	N/A
MB18HHE13	Prefabricated metal steps, 4-risers / each	\$750/ea	N/A	N/A	N/A	N/A	N/A	N/A
MB18HHE14	Step assembly or disassembly cost	\$ 1,250.00	N/A	N/A	N/A	N/A	N/A	N/A
MB18HHE15	Towbar Removal or Installed, Each	\$650/ea	N/A	N/A	N/A	N/A	N/A	N/A
MB18HHE16	Axles Removed or Installed, Each	\$ 2,500.00	N/A	N/A	N/A	N/A	N/A	N/A
MB18HHE17	Tires Removed or Installed, Each	\$ 2,000.00	N/A	N/A	N/A	N/A	N/A	N/A
MB18HHE18	Std. Ser. Rate Per Hour - Except: Overtime & Holidays	\$ 2,400.00	N/A	N/A	N/A	N/A	N/A	N/A
Add	Standard Delivery and Set Up	\$ 6,712.00						



WESTE
OAKS
TMENT



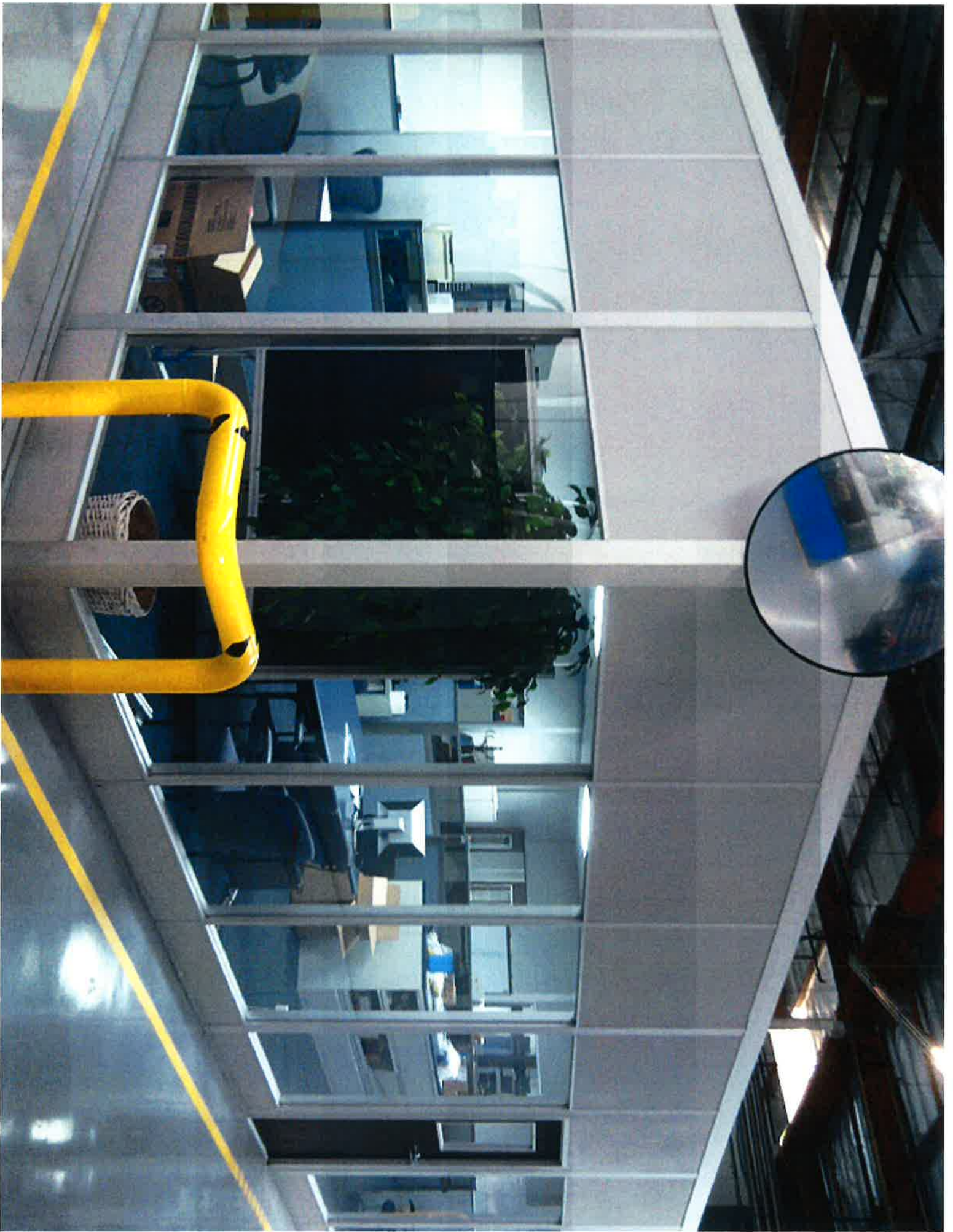



Falcon Containers



LEFT WALL

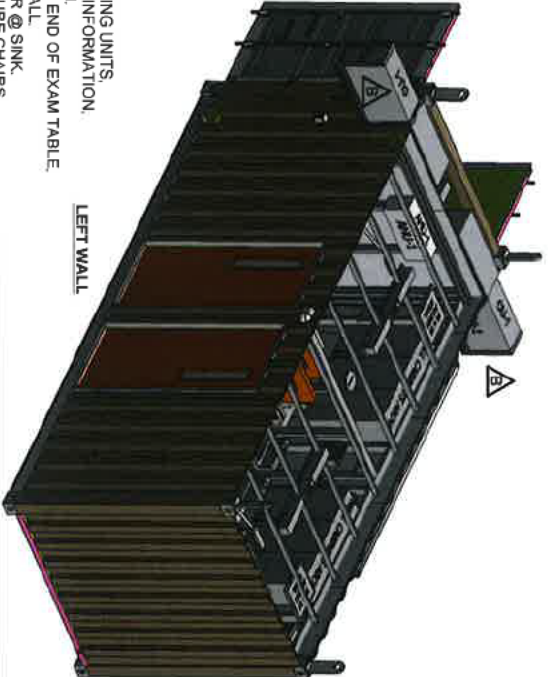

LEFT WALL

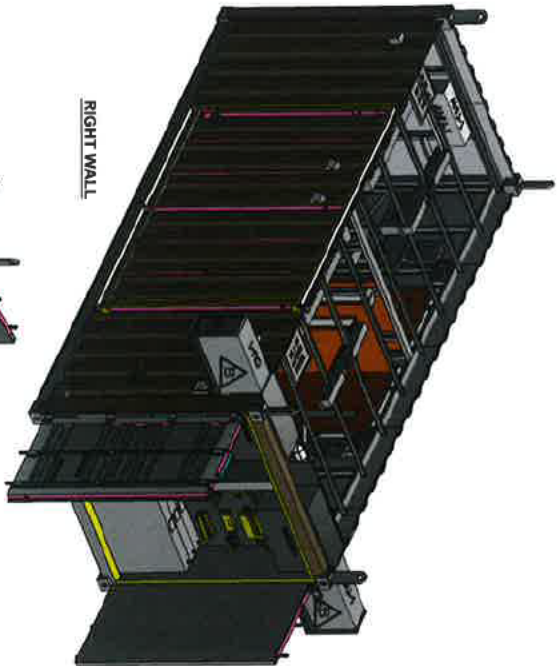

RIGHT WALL



RIGHT WALL

EXTERIOR ISO VIEWS

- NOTES:**
1. ADDED COLLAPABLE CONDENSING UNITS.
 2. SEE GENERIC DWG FOR MORE INFORMATION.
 3. ADDED HOLDING TANK & DRAIN.
 4. MOVE DIAGNOSTIC SYSTEM TO END OF EXAM TABLE.
 5. MOVE GLOVE BOX TO DOOR WALL.
 6. ADDED FOLDED TOWEL HOLDER @ SINK.
 7. ADDED VELCRO STRAP TO SECURE CHAIRS.
 8. LOWERED WATER TANK 22".

TSG INDUSTRIES
2200 NORTH LOOP WEST, STE. 102
HOUSTON TEXAS 77018

CAMP SWIFT
MEDICAL UNIT RENDERING
SEE BOX ASSY FOR
MEDICAL UNIT RENDERING

REV	BY	DESCRIPTION	DATE	SERIES	MEDICAL	SHEET	OF
B	RKH	I/A - REV PER NOTES SHEET 1	01/11/20	LOG NO. CAMP SWIFT	MANO: MEDICAL	1	5
A	RKH	I/A - ISSUE FOR APPROVAL	11/26/19	LM DESCRIPTION:			



**Region 5 ESC - "Portable Building, Ramping, Supplies and/or Services" Catalog/Price List for
Contract Year of November 1, 2020 to October 31, 2021.**

		Installed	Rental	Monthly
		Price	Install	Rent
ENTRADA Commercial Ramp Series				
RAMP SECTIONS - 48" wide Picket Rails				
ES248PR	Entrada Commercial Modular Ramp 2' x 48" with 42" Guard Rails	\$ 508.49	\$ 40.00	\$ 15.04
ES348PR	Entrada Commercial Modular Ramp 3' x 48" with 42" Guard Rails	\$ 699.23	\$ 60.00	\$ 22.56
ES448PR	Entrada Commercial Modular Ramp 4' x 48" with 42" Guard Rails	\$ 883.19	\$ 80.00	\$ 30.08
ES548PR	Entrada Commercial Modular Ramp 5' x 48" with 42" Guard Rails	\$ 1,023.66	\$ 100.00	\$ 37.60
ES648PR	Entrada Commercial Modular Ramp 6' x 48" with 42" Guard Rails	\$ 1,251.20	\$ 120.00	\$ 45.12
RAMP SECTIONS - 54" wide Picket Rails (48" clear width)				
ES254PR	Entrada Commercial Modular Ramp 2' x 54" with 42" Guard Rails	\$ 620.20	\$ 45.00	\$ 16.92
ES354PR	Entrada Commercial Modular Ramp 3' x 54" with 42" Guard Rails	\$ 831.16	\$ 67.50	\$ 25.38
ES454PR	Entrada Commercial Modular Ramp 4' x 54" with 42" Guard Rails	\$ 1,053.68	\$ 90.00	\$ 33.84
ES554PR	Entrada Commercial Modular Ramp 5' x 54" with 42" Guard Rails	\$ 1,227.12	\$ 112.50	\$ 42.30
ES654PR	Entrada Commercial Modular Ramp 6' x 54" with 42" Guard Rails	\$ 1,498.97	\$ 135.00	\$ 50.76
PLATFORMS - 42" Tall Picket Rails				
ES44PR	Entrada Commercial Modular Platform 4' x 4' with 42" Guard Rails	\$ 883.19	\$ 80.00	\$ 30.80
ES45TPR	Entrada Commercial Modular Platform 4' x 5' Turn with 42" Rails	\$ 1,315.32	\$ 100.00	\$ 37.60
ES45E4PR	Entrada Commercial Modular Platform 4' x 5' 4' side Entry with 42" Guard Rails	\$ 1,308.59	\$ 100.00	\$ 37.60
ES45E5PR	Entrada Commercial Modular Platform 4' x 5' 5' side Entry with 42" Guard Rails	\$ 1,285.09	\$ 100.00	\$ 37.60
ES55PR	Entrada Commercial Modular Platform 5' x 5' with 42" Guard Rails	\$ 1,508.93	\$ 125.00	\$ 47.00
ES56TPR	Entrada Commercial Modular Platform 6' x 5' 5' Turn with 42" Guard Rails	\$ 1,635.88	\$ 150.00	\$ 56.40
ES56E5PR	Entrada Commercial Modular Platform 6' x 5' 5' side Entry with 42" Guard Rails	\$ 1,661.79	\$ 150.00	\$ 56.40
ES56E6PR	Entrada Commercial Modular Platform 6' x 5' 6' side Entry with 42" Guard Rails	\$ 1,671.78	\$ 150.00	\$ 56.40
ES66PR	Entrada Commercial Modular Platform 6' x 6' with 42" Guard Rails	\$ 1,727.88	\$ 180.00	\$ 67.68
ACCESSORIES				
ASB	Angle Support Bracket (over 30" height use)	\$ 11.00		
BPCOM	Bridge Plate 3" x 45.25"	\$ 49.98	\$ 20.00	\$ 7.52
ESCORPR	Entrada Platform Corner Kit Picket Railing 42" Tall	\$ 60.18		
ESLOOP	Entrada Handrail Loop	\$ 38.76		
GRBRK	Grab Rail bracket	\$ 24.48		
GRBTF	Grab Rail by the Foot	\$ 4.08		
HTDK	Hurricane Tie Down Kit	\$ 25.00		
LRK	Lightening Rod Kit	\$ 72.00		
TPCOM	Transition Plate 9.25" x 48"	\$ 70.38	\$ 20.00	\$ 7.52
TT48	Transition Tread 48" x 12"	\$ 93.00	\$ 20.00	\$ 7.52
TT54	Transition Tread 54" x 12"	\$ 111.00	\$ 22.50	\$ 8.46
TT60	Transition Tread 60" x 12"	\$ 114.00	\$ 25.00	\$ 9.40
ES2T48	Entrada Commercial Step 2 Tread, 48" wide closed risers with 42" Guard Rail	\$ 767.01	\$ 40.00	\$ 15.04
ES3T48	Entrada Commercial Step 3 Tread, 48" wide closed risers with 42" Guard Rail	\$ 1,163.48	\$ 60.00	\$ 22.56
ES4T48	Entrada Commercial Step 4 Tread, 48" wide closed risers with 42" Guard Rail	\$ 1,524.81	\$ 80.00	\$ 30.08
ES5T48	Entrada Commercial Step 5 Tread, 48" wide closed risers with 42" Guard Rail	\$ 1,881.43	\$ 100.00	\$ 37.60
ES6T48	Entrada Commercial Step 6 Tread, 48" wide closed risers with 42" Guard Rail	\$ 2,237.47	\$ 120.00	\$ 45.12

ES7T48	Entranda Commercial Step 7 Tread, 48" wide closed risers with 42" Guard Rail	\$ 2,601.59	\$ 140.00	\$ 52.64
ES8T48	Entranda Commercial Step 8 Tread, 48" wide closed risers with 42" Guard Rail	\$ 2,965.65	\$ 160.00	\$ 60.16
ES9T48	Entranda Commercial Step 9 Tread, 48" wide closed risers with 42" Guard Rail	\$ 3,336.36	\$ 180.00	\$ 67.68
ES10T48	Entranda Commercial Step 10 Tread, 48" wide closed risers with 42" Guard Rail	\$ 3,929.42	\$ 200.00	\$ 75.20
Vertical Platform Lifts				
VPL156	DC Battery Operated VPL, 36 x 54" Platform, 78" Tower Height, 156" Lifting Height, 750 lb Weight Capacity. (Includes Platform Gate w/ interlock) Includes Adjustable Side Mounting Bracket. Includes Automatic Emergency Lowering system.	\$15,150	n/a	n/a
VPL105	DC Battery Operated VPL, 36 x 54" Platform, 135" Tower Height, 105" Lifting Height, 750 lb Weight Capacity. (Includes Platform Gate w/ interlock) Includes Adjustable Side Mounting Bracket. Includes Automatic Emergency Lowering system.	\$13,250	n/a	n/a
VPL3214	VPL-3214B: Automatic self-lowering folding ramp, Weather-resistant finish and controls, Emergency stop switch on platform safety sensors in platform bottom, DC battery power, 14-ft	\$18,500	n/a	n/a
Note:	VPL pricing does not include permits, full enclosures or electrical outlets			
Stairlifts				
SL300/16	SL300 Commercial stairlift. Weight Cap. 300Lbs. Upto 16' track	\$5,795	n/a	n/a
SL300/20	SL300 Commercial stairlift. Weight Cap. 300Lbs. Upto 20' track	\$6,135	n/a	n/a
SL400/16	SL400 Heavy Duty Commercial stairlift. Weight Cap. 400Lbs. Upto 16' track	\$7,295	n/a	n/a
SL400/20	SL400 Heavy Duty Commercial stairlift. Weight Cap. 400Lbs. Upto 20' track	\$7,635	n/a	n/a
Curve	Pricing varies			
Grab bars				
Any Size	Includes any size (standard SS grab bar) and installation	\$120	n/a	n/a
Pool Lifts				
Scout 2	Scout 2 pool lift features an adjustable height seat pole. Weight capacity of 375 pounds.	\$5,974	n/a	n/a
Mighty 400	The Mighty 400 Lift designed to provide versatility and accessibility solutions with a water draft of 12 inches and a setback up to 44 inches. Weight capacity 400 pounds	\$5,974	n/a	n/a
Ranger 2	The Ranger 2 is field reversible design, 350 pound weight capacity, UL Certification, and comes standard with a 14 inch deck to water draft.	\$3,295	n/a	n/a
Portable	Portable Pro Pool 2 is completely portable and has a 350 pound weight capacity and incorporates several key features of our more popular lifts.	\$7,999	n/a	n/a

Code Compliant Steps

OSHA and General Code

General Code Steps

- All aluminum construction
- Landing and stairs designed for 100 psf live load and a concentrated load of 300 lbs.
- Hand/Guard rails designed for 200 lbs. force applied at any point along top of rail
- Welding is performed in accordance with ANSI/AWS D 1.2-97 GMAW process by experienced operators
- Assembles in less than 15 minutes
- All components are universal to be relocated and assembled for doorway at either side of building
- Slip-resistant self-draining interlocking aluminum deck



Dura-Grip™ General Code Steps
(29" to 49")



Dura-Grip™ OSHA Code Steps
(25" to 35")



OSHA Code Flex Step
(28"/35" or 42"/49")



OSHA Code Fixed Step
(30")

OSHA Grade Steps

- All aluminum construction
- Landing and stairs designed for 100 psf live load and a concentrated load of 300 lbs.
- Hand/Guard rails designed for 200 lbs. force applied at any point along top of rail
- Welding is performed in accordance with ANSI/AWS D 1.2-97 GMAW process by experienced operators
- Assembles in less than 10 minutes
- All components are universal to be relocated and assembled for doorway at either side of building
- Slip-resistant self-draining interlocking aluminum deck

- Slip-resistant **Dura-Grip™** deck
- Independently adjustable legs
- No painting or corrosion
- Long life cycle
- Minimal parts and maintenance free
- ADA ramps and platforms also available









All Aluminum Access Systems

www.reddteam.com

125 Superior Drive • Delhi, LA 71232 • 800.648.3696

REDD
TEAM
by Supa



CULTURENUITY

Item	Type	Item #	Qty	Price	Cost
Mission Solar 315 Mono PERC Solar Panels	Solar Panels	1945515		\$250.00	\$0.00
Heyco Products Inc. HEYClip Sunrunner Cable Clip - S-6405 - Single	Racking	7500013		\$2.00	\$0.00
IronRidge XR100 Roof Mount Racking Kit	Racking	6913221		\$400.00	\$0.00
MNSW4048-CL150 Schneider Pre-wired Power CenterMidNite Solar	Power Centers	8925055		\$4,000.00	\$0.00
MNSW2524-KID-B Pre-Wired System	Power Centers				\$0.00
Electrical Design Diagram	Services	9000129			\$0.00
MidNite Solar MNEPV-20	Breakers	8541202		\$30.00	\$0.00
MidNite Solar Waterproof Strain Relief With 2 Holes, 0.25 to 0.27" Cable Di. Cables	Cables	9932526		\$6.00	\$0.00
Other Manufacturer Waterproof Strain Relief With One Hole	Cables	9932435		\$6.00	\$0.00
4/0 - 120" UL Cable (Red)	Cables	9911208		\$200.00	\$0.00
4/0 - 120" UL Cable (White)	Cables	9901208		\$200.00	\$0.00
MC4 10 AWG - 50' Cable Extension	Cables	9994165		\$55.00	\$0.00
Multi-Contact USA MC4 Unlocking Tool	Tool	9981081		\$7.00	\$0.00
MidNite Solar MNSPD-300-DC	Surge Suppressor	9930041		\$125.00	\$0.00
Outback EnergyCell 200Ah 12V Nano-Carbon AGM Battery w/ Front Terminal 200NC	battery	9930041		\$700.00	\$0.00
MidNite Solar MNPV6	Combiner Box	8910041		\$140.00	\$0.00
Total Cost					\$0.00

Shipping \$1,350.00
 Total \$1,795.50



Item	Type	Item #	Qty	Price	Cost
Mission Solar 315 Mono PERC Solar Panels	Solar Panels	1945515		\$250.00	\$0.00
Heyco Products Inc. HEYClip Sunrunner Cable Clip - S-6405 - Single	Racking	7500013		\$2.00	\$0.00
IronRidge XR100 Roof Mount Racking Kit	Racking	6913221		\$400.00	\$0.00
MNSW4048-CL150 Schneider Pre-wired Power CenterMidNite Solar	Power Centers	8925055		\$4,000.00	\$0.00
MNSW2524-KID-B Pre-Wired System	Services	9000129			\$0.00
Electrical Design Diagram	Breakers	8541202		\$30.00	\$0.00
MidNite Solar MNEPV-20	Cables	9932526		\$6.00	\$0.00
MidNite Solar Waterproof Strain Relief With 2 Holes, 0.25 to 0.27" Cable Di	Cables	9932435		\$6.00	\$0.00
Other Manufacturer Waterproof Strain Relief With One Hole	Cables	9911208		\$200.00	\$0.00
4/0 - 120" UL Cable (Red)	Cables	9901208		\$200.00	\$0.00
4/0 - 120" UL Cable (White)	Cables	9994165		\$55.00	\$0.00
MC4 10 AWG - 50' Cable Extension	Tool	9981081		\$7.00	\$0.00
Multi-Contact USA MC4 Unlocking Tool	Surge Suppressor	9930041		\$125.00	\$0.00
MidNite Solar MNSPD-300-DC		9930041			
Outback EnergyCell 200Ah 12V Nano-Carbon AGM Battery w/ Front	battery			\$700.00	\$0.00
Terminal 200NC	Combiner Box			\$140.00	\$0.00
MidNite Solar MNPV6		8910041			\$0.00
Total Cost				Shipping	\$1,350.00

SLP090-12U

High Efficiency Multicrystalline PV Module

Electrical Characteristics	SLP090-12U
Product code	090011202
Maximum power (Pmax)	90W
Voltage at Pmax (Vmp)	17.2V
Current at Pmax (Imp)	5.23A
Open-circuit voltage (Voc)	21.6V
Short-circuit current (Isc)	5.81A
Temperature coefficient of Voc	-(80±10)mV/°C
Temperature coefficient of Isc	(0.065±0.015)%/°C
Temperature coefficient of power	-(0.5±0.05)%/°C
NOCT (Air 20°C; Sun 0.8kW/m² wind 1m/s)	47±2°C
Operating temperature	-40°C to 85°C
Maximum system voltage	1000V DC
Power tolerance	± 5%

*STC: Irradiance 1000W/m², AM1.5 spectrum, module temperature 25°C
*NOCT: Nominal operating cell temperature (the data is only for reference)



Module Diagram

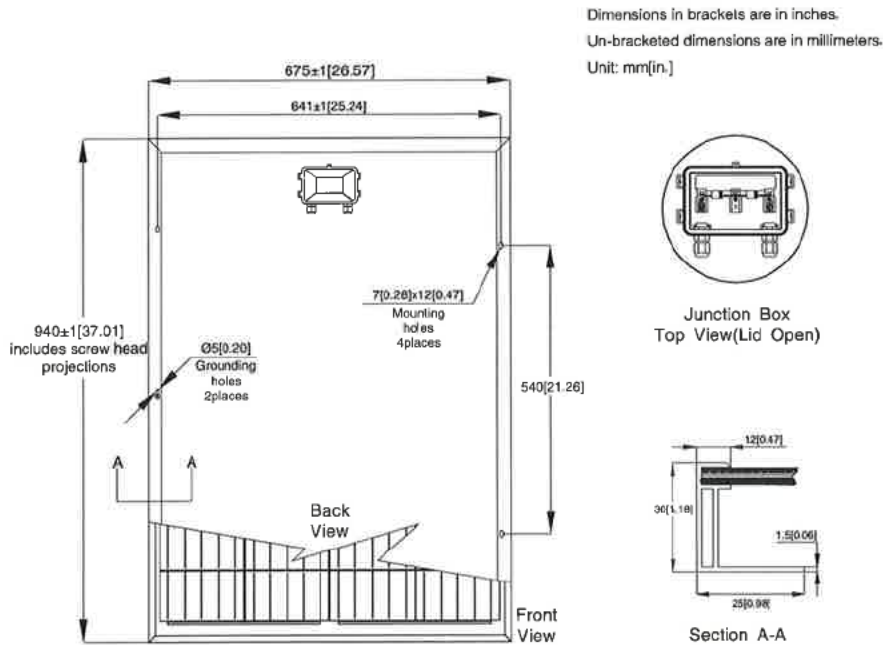

Features

- Nominal 12V DC for standard output.
- Outstanding low-light performance.
- Heavy-duty anodized frames.
- High transparent low-iron,tempered glass.
- Rugged design to withstand high wind pressure, hail and snow load.
- Aesthetic appearance.

Characteristics

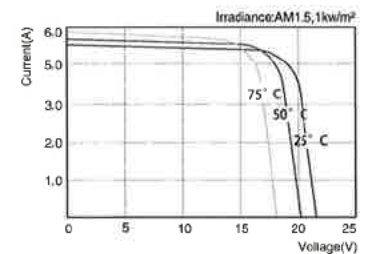

Specifications	SLP090-12U
Cells	Polycrystalline silicon solar cell
No. of cells and connections	36(4X9)
Module dimension	940mm[37.01in.],x675mm[26.57in.],x30mm[1.18in.]
Weight	8.00kg[17.64lbs]
Packing information(Carton)	980mm[38.58in.],x715mm[28.15in.],x80mm[3.15in.]/(2pcs/ctn)

*Limited warranty: 5-year limited warranty of materials and workmanship; 10-year limited warranty of 90% power output; 25-year limited warranty of 80% power output. For detail, please contact us.
*Specifications are subject to change without notice at any time.

Clean Room Equipment & Furniture

Disposable Dispensers

Wall-mounted dispensers are designed to provide efficient dispensing and storage of Gloves, Hairnets, Facemasks, Booties, etc. Units are electropolished 304 stainless steel and each compartment is approximately 200mm x 200mm x 600 mm (or 1000 mm) tall.

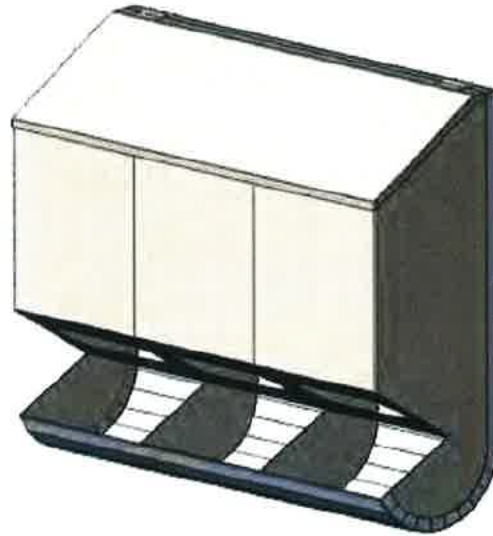

Ordering Information

Part number example: DD-n-hhhh-t

- n is number of compartments.
- hhhh is the height in mm(e.g. 0600 for 600 mm).
- t is the adder for top configuration (add S for sloping top).

Disposable Dispensers				
Part Number	Compartments	LxWxH (mm)	LxWxH (inch)	Top Config
DD-1-0600	1	200x205x600	8x8x24	Flat
DD-2-0600	2	400x205x600	16x8x24	Flat
DD-3-0600	3	600x205x600	24x8x24	Flat
DD-4-0600	4	800x205x600	32x8x24	Flat
DD-1-1000	1	200x205x1000	8x8x39	Flat
DD-2-1000	2	400x205x1000	16x8x39	Flat
DD-3-1000	3	600x205x1000	24x8x39	Flat
DD-4-1000	4	800x205x1000	32x8x39	Flat
DD-1-0600-S	1	200x205x600	8x8x24	Sloped
DD-2-0600-S	2	400x205x600	16x8x24	Sloped
DD-3-0600-S	3	600x205x600	24x8x24	Sloped
DD-4-0600-S	4	800x205x600	32x8x24	Sloped
DD-1-1000-S	1	200x205x1000	8x8x39	Sloped
DD-2-1000-S	2	400x205x1000	16x8x39	Sloped
DD-3-1000-S	3	600x205x1000	24x8x39	Sloped
DD-4-1000-S	4	800x205x1000	32x8x39	Sloped

Clean Room Equipment & Furniture

Sterile Glove Dispensers

Wall mounted dispensers are designed to provide efficient dispensing and storage of sterile packaged gloves. Units are electropolished 304 stainless steel and each compartment is sized to fit packages. Units may have multiple slots and may stack packages.

Ordering Information

Part number example: SGD-x-y-ssss-t

- x is number of compartments.
- y is the stack height (in number of packages).
- ssss is the size of the packages in inches (e.g. 0607 for 6x7 or 1106 for 11x6).
- t is the adder for top configuration (add S for sloping top).

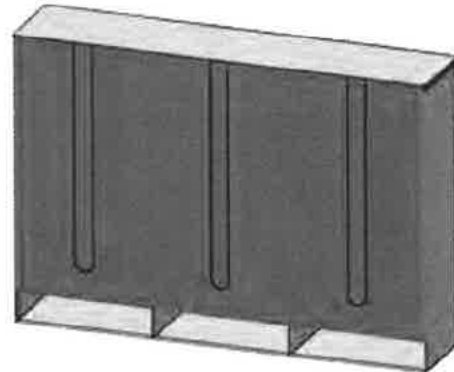

Sterile Glove Dispensers

Part Number	Cmpprt	Stk Ht	LxWxH (mm)	LxWxH (inch)	Top
SGD-4-6-0607	4	6	680x205x600	27x8x24	Flat
SGD-3-6-1106	3	6	870x180x600	34.5x7x24	Flat

Eye Glass Dispensers

Wall mounted dispensers are designed to provide efficient dispensing and storage of eye glasses or other similar sized items. Units are electropolished 304 stainless steel with clear fronts.

Ordering Information

Part number example: EGD-ll-ww-hh

- ll is length of the dispenser (cm).
- ww is width of the dispenser (cm).
- hh is height of the dispenser (cm).

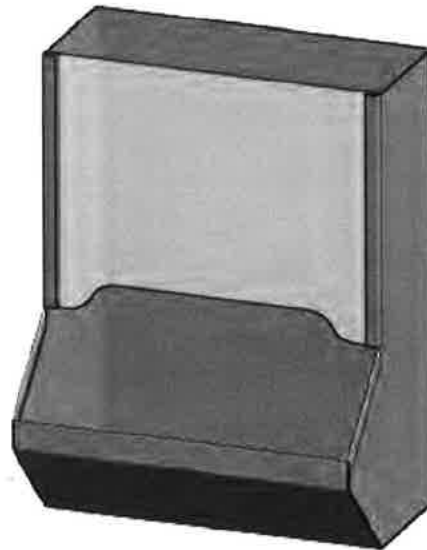

Eye Glass Dispensers

Part Number	LxWxH (mm)	LxWxH (inch)
EGD-30-20-40	300x200x400	12x8x16

Clean Room Equipment & Furniture

Gown and Hood Dispensers

Wall mounted dispensers are designed to provide efficient dispensing and storage of folded gowns or wrapped gowns and hoods. Units are electropolished 304 stainless steel and units for folded items will have partially open fronts to facilitate loading of folded garments.



Ordering Information

Part number example: GHD-ll-ww-hh-w

- ll is length of the dispenser (cm).
- ww is width of the dispenser (cm).
- hh is height of the dispenser (cm).
- w is the adder for front configuration (add W for wrapped item dispensing).

Gown and Hood Dispensers

Part Number	LxWxH (mm)	LxWxH (inch)	Front Config
GHD-35-25-75	350x250x750	14x10x29.5	Folded
GHD-41-31-75	410x310x750	16x12x30	Folded
GHD-30-24-80-W	300x240x800	12x9.5x32	Wrapped

Disposal / Recycle Cabinets

Cabinets are designed to provide efficient disposal / recycle of cleanroom items. Units are electropolished 304 stainless steel with removable waste bins.



Ordering Information

Part number example: DRC-ll-ww-hh

- ll is length of the dispenser (cm).
- ww is width of the dispenser (cm).
- hh is height of the dispenser (cm).

Disposal / Recycle Cabinets

Part Number	LxWxH (mm)	LxWxH (inch)
DRC-80-43-90	800x430x900	32x17x36

Clean Room Equipment & Furniture

Stainless Steel Stools

Stools are designed to be a totally stainless steel solution. Units are electropolished 304 stainless steel and may be provided with fixed height or adjustable. Fixed height stools have 600 mm round seats and are 500 mm high. Adjustable stools can be set between 450 mm and 580 mm high. Stools are available with gliders, casters or feet to fix the stool to the floor.

Ordering Information

Part number example: SSS-f-a

- f is the adder for foot configuration (add C for casters, G for Gliders and F for fixed to floor).
- a is the adder for adjustable configuration (add A for adjustable height stool).

Stainless Steel Stools

Part Number	Base/Feet	Height	LxWxH (mm)	LxWxH (inch)
SSS-C	Casters	Fixed	600x600x500	24x24x20
SSS-F	Fixed to Floor	Fixed	600x600x500	24x24x20
SSS-G	Gliders	Fixed	600x600x500	24x24x20
SSS-C-A	Casters	Adjustable	600x600x500	24x24x20
SSS-F-A	Fixed to Floor	Adjustable	600x600x500	24x24x20
SSS-G-A	Gliders	Adjustable	600x600x500	24x24x20



Clean Room Equipment & Furniture

Heavy Duty Tables

Tables are designed strong with solid tops and leveler legs. Tables are 760 mm wide x 900 mm high. Units are electropolished 304 stainless steel and may be provided with optional perforated top, bottom shelf, top shelf, drawer unit, sliding keyboard holder, flat screen holder and/or casters.

Ordering Information

Part number example: HDT-III-pbtndksc

- III is length of the table (cm).
 - p is the adder for perforated top (add P).
 - b is the adder for bottom shelf (add B).
 - t is the adder for top shelf (add T).
 - nd is the adder for drawer unit where n is the number of drawers (add 1D, 2D or 3D).
 - k is the adder for keyboard holder (add K).
 - s is the adder for flat screen holder (add S).
 - c is the adder for feet configuration (add C for casters and L for levelers with covers).
- If omitted, tables will be supplied with adjustable gliders.



Heavy Duty Tables - Solid Top w/Gliders

Part Number	Top	Shlf	Dwr	Kybrd / Flt Scrn	LxWxH (mm)	LxWxH (inch)	Base / Feet
HDT-060	Solid	none	none	none	600x760x900	24x30x36	Glider
HDT-070	Solid	none	none	none	700x760x900	28x30x36	Glider
HDT-080	Solid	none	none	none	800x760x900	32x30x36	Glider
HDT-090	Solid	none	none	none	900x760x900	36x30x36	Glider
HDT-100	Solid	none	none	none	1000x760x900	40x30x36	Glider
HDT-110	Solid	none	none	none	1100x760x900	44x30x36	Glider
HDT-120-L	Solid	none	none	none	1200x760x900	48x30x36	Leveler
HDT-130-L	Solid	none	none	none	1300x760x900	52x30x36	Leveler
HDT-140-L	Solid	none	none	none	1400x760x900	55x30x36	Leveler
HDT-150-L	Solid	none	none	none	1500x760x900	59x30x36	Leveler
HDT-160-L	Solid	none	none	none	1600x760x900	63x30x36	Leveler
HDT-170-L	Solid	none	none	none	1700x760x900	67x30x36	Leveler
HDT-180-L	Solid	none	none	none	1800x760x900	71x30x36	Leveler
HDT-190-L	Solid	none	none	none	1900x760x900	75x30x36	Leveler
HDT-200-L	Solid	none	none	none	2000x760x900	79x30x36	Leveler

Clean Room Equipment & Furniture

Heavy Duty Tables - Perforated Top w/Levelers and Covers

Part Number	Top	Shlf	Dwr	Kybrd / Flt Scrn	LxWxH (mm)	LxWxH (inch)	Base / Feet
HDT-060-P	Perf	none	none	none	600x760x900	24x30x36	Glider
HDT-070-P	Perf	none	none	none	700x760x900	28x30x36	Glider
HDT-080-P	Perf	none	none	none	800x760x900	32x30x36	Glider
HDT-090-P	Perf	none	none	none	900x760x900	36x30x36	Glider
HDT-100-P	Perf	none	none	none	1000x760x900	40x30x36	Glider
HDT-110-P	Perf	none	none	none	1100x760x900	44x30x36	Glider
HDT-120-PL	Perf	none	none	none	1200x760x900	48x30x36	Leveler
HDT-130-PL	Perf	none	none	none	1300x760x900	52x30x36	Leveler
HDT-140-PL	Perf	none	none	none	1400x760x900	55x30x36	Leveler
HDT-150-PL	Perf	none	none	none	1500x760x900	59x30x36	Leveler
HDT-160-PL	Perf	none	none	none	1600x760x900	63x30x36	Leveler
HDT-170-PL	Perf	none	none	none	1700x760x900	67x30x36	Leveler
HDT-180-PL	Perf	none	none	none	1800x760x900	71x30x36	Leveler
HDT-190-PL	Perf	none	none	none	1900x760x900	75x30x36	Leveler
HDT-200-PL	Perf	none	none	none	2000x760x900	79x30x36	Leveler

Heavy Duty Tables - w/Accessories

Part Number	Top	Shlf	Dwr	Kybrd / Flt Scrn	LxWxH (mm)	LxWxH (inch)	Base / Feet
HDT-060-T2D	Solid	Top	2	none	600x760x900	24x30x36	Glider
HDT-080-B	Solid	Bot	none	none	800x760x900	32x30x36	Glider
HDT-120-1DC	Solid	none	1	none	1200x760x900	48x30x36	Caster
HDT-150-2D	Solid	none	2	none	1500x760x900	59x30x36	Glider
HDT-180-T3DL	Solid	Top	3	none	1800x760x900	71x30x36	Leveler
HDT-150-1DKS	Solid	none	1	Kb&FS	1500x760x900	59x30x36	Glider
HDT-200-BTL	Solid	B&T	none	none	2000x760x900	79x30x36	Leveler

Drawer Units

Fully extendable drawer units with locks can be supplied for most any table and can be connected anywhere underneath a Heavy Duty Table. Units are electropolished 304 stainless steel.

Ordering Information

Part number example: DU-n

- n is the adder for number of drawers (add 1, 2 or 3).
- Example: DU-3 dictates a 3-drawer unit.



Clean Room Equipment & Furniture

Storage Cabinets

Storage cabinets are designed with internal shelves. Units are electropolished 304 stainless steel and may be provided sloping roof and with 1, 2 or 4 doors. Doors may be stainless or glass, hinged or sliding designs. Cabinets may be wall mounted, have leveler legs or have casters.

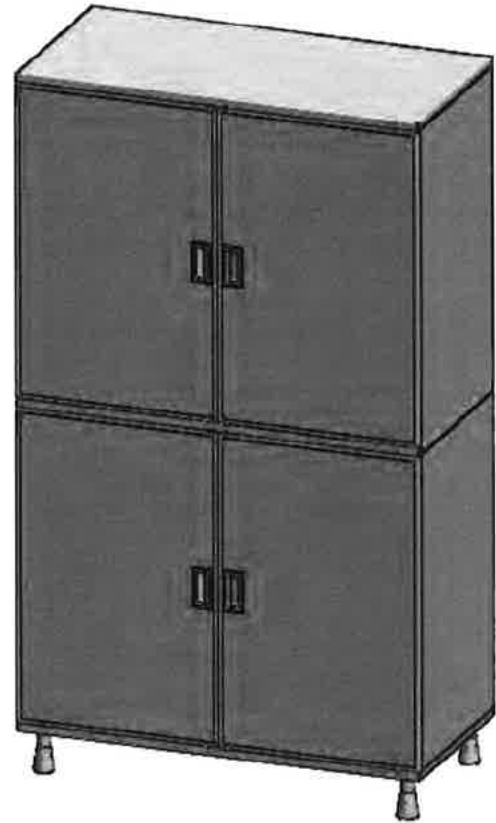

Ordering Information

Part number example: SCt-III-www-hhh-nsm-v-clw

- t is the adder for sloping roof.
- III is length of the cabinet (cm).
- www is length of the cabinet (cm).
- hhh is length of the cabinet (cm).
- n is the number of doors.
- s is the door style (H for hinged, S for sliding).
- m is the door material (M for stainless, G for tempered glass).
- v is the number of shelves.
- c is the adder for casters (add C).
- l is the adder for leveler legs (add L).
- w is the adder for wall mount (add W).

Storage Cabinets

Part Number	Roof	LxWxH (mm)	LxWxH (inch)	Door	Shelves	Feet / Mount
SCT-100-038-200-4HM-6-L	Sloped	1000x380x2000	40x15x79	4 SS Hinged	6	Levelers w/covers
SCT-120-045-200-4HM-6-L	Sloped	1200x450x2000	48x18x79	4 SS Hinged	6	Levelers w/covers
SC-120-060-210-2HM-6-L	Flat	1200x600x2100	48x24x83	2 SS Hinged	6	Levelers w/covers
SC-120-060-210-2HM-6-C	Flat	1200x600x2100	48x24x83	2 SS Hinged	6	Casters
SC-090-060-210-2HM-4-L	Flat	900x600x2100	36x24x83	2 SS Hinged	4	Levelers w/covers
SC-090-060-210-2HM-4-C	Flat	900x600x2100	36x24x83	2 SS Hinged	4	Casters
SC-091-048-150-2HM-3-L	Flat	910x483x1500	36x19x60	2 SS Hinged	3	Levelers w/covers
SC-091-048-150-2HM-3-C	Flat	910x483x1500	36x19x60	2 SS Hinged	3	Casters

Region 4 Education Service Center

Modular Buildings, Portable Storage, and Relocatable Walkways

Solicitation Number 21-05

TAB 2

Performance Capability



BUILDING CAPITAL SOLUTIONS

Capability Statement

<p>(1) Core Competencies What is your niche in the market place?</p> <p>Our niche areas include As a TDLR certified company. TSG Industries focuses on sustainable construction, pre-fabricated and modular building services.</p> <p>(2) Capacity What is your ability to manage projects? TSG Industries leaders have delivered federal, public and local building solutions in Texas.</p> <p>What is your technical ability? Our people have an average of 30 years experience in design, construction, engineering of public buildings.</p> <p>What equipment do you have? TSG Industries construction and logistics equipment at central operations in Houston, Texas.</p> <p>What is the staff size? 8</p> <p>How do you finance your projects? TSG Industries, a small business owner, has partnered with Small Business Administration for capital finance solutions with cooperation from our banks.</p> <p>How do you mitigate risk? TSG Industries over the years has established Lessons Learned from client feedback. Team communication is most important for the best results.</p>	<p>D&B #: 078679713</p> <p>Cage Code: 6TTS6</p> <p>Website: www.tsg-industries.com</p> <p>LinkedIn page: https://www.linkedin.com/company/8589159/admin/</p> <p>You Tube address: N/A</p> <p>Primary NAICS: 236220, 332311</p> <p>Primary PSC: 5410 Prefabricated and Portable Buildings</p> <p>Year Business Started: 2007</p> <p>Socio Economic Certification:</p> <p>Small Business Enterprise (SBE) Minority Business Enterprise (MBE) Disadvantaged Business Enterprise (DBE) Historically Underutilized Business (HUB)</p> <p>Bonding/Insurance:</p> <p>\$2,000,000 aggregate bonding \$1,000,000 Workers Compensation \$1,000,000 General Liability \$500,000 Auto Liability</p> <p>Quality Certifications:</p> <p>Occupational Safety Health Administration (OSHA) Plan-Act-Check-Excel (PACE) Texas Department of Licensing and Regulation (TDLR) Inspection & Testing Plans (ITP) Windstorm Certification</p>
---	---

2200 North Loop West, Ste. 102
Houston, TX 77018
Phone (888) 586-2703
www.tsg-industries.com



BUILDING CAPITAL SOLUTIONS

<p>Who are your teaming partners? TSG Industries is open to new and unique opportunities for greater impact.</p> <p>(3) Past performance How well did you perform on a similar project? Animal Plant Health Inspection Service, Houston Station Period of performance: 09/2017-03/2020 Contract number: AG-32KW-C-17-0022 Contracting office: Margaux G. Nenichka margaux.g.nenichka@usda.gov</p> <p>Contract Award/Completion Date: 09/2017-03/2020 Dollar value \$298,408.27 Type of contract Design-Build</p> <p>(4) Past experience (A) Texas Southern University, Dan Williams, Project Manager Dan.Williams@tsu.edu</p> <p>(B) Bastrop Animal Hospital, Emergency Shawn Harris, Facility Director shawn.harris@co.bastrop.tx.us</p> <p>(C) Harris Health System, Ben Taub Jason Kunnacherry, Project Director Jason.Kunnacherry@harrishealth.org</p>	<p>Contract Vehicles: Yes</p> <p>Business Certifications: Texas Department of Licensing and Regulation (TDLR) Leadership in Energy and Environmental Design (LEED)</p> <p>Accept credit cards: N/A</p> <p>Office Locations:</p> <p>Dallas Office: 1341 W. Mockingbird Lane, Suite 600W Dallas, Texas 75247</p> <p>Houston Office (Headquarters): 2200 North Loop West, Suite 102 Houston, Texas 77018</p> <p>Contact Name: Theodore "Ted" Sims, LEED AP Email: tsims@tsg-industries.com Cell #: (832) 660-5914</p>
--	--

2200 North Loop West, Ste. 102
Houston, TX 77018
Phone (888) 586-2703
www.tsg-industries.com



**AMERICAN
SURETY**

15814 Lower Lake Drive
Cypress, Texas 77433
Office: 281/256-3830
Fax: 281/256-3832
TimKirk7@comcast.net

November 2, 2020

To: Theodore Sims
TSG Industries LLC
7040 Rook Blvd.
Houston, Texas 77087

RE: TIPS Job Order Contract

To Whom It May Concern,

Please be advised that American Surety Agency recognizes TSG Industries LLC as a capable and competent company. We agree to be the surety agent, and will utilize SBA Surety Bond Guarantee Program on public, state, and federal project bonding requirements.

We will consider a bonding need up to \$500,000 single/ \$1,000,000 aggregate. As always, the Surety reserves the right to perform normal underwriting at the time of any bond request, including, without limitation, prior review and approval of relevant.

If you have any questions, please contact our office.

Sincerely,

Tim Kirk, Partner

project, the PAC will provide community residents with professional and career development opportunities and serve as a community resource center for other service providing non-profit and impact agencies.

Cristo Rey St. Viator High School – Cristo Rey St. Viator (North Las Vegas, NV)

\$15M NMTC Transaction – Closed 2018

Cristo Rey Network is comprised of 32 independent catholic high schools spread across 21 states and the District of Columbia, all committed to the education of America's disadvantaged youth. The network has 20 years of experience serving young men and women from economically disadvantaged communities and families, helping to guide and support healthy life trajectories through education. The newest addition to the network is Cristo Rey St. Viator and its 98,000 SF educational campus in North Las Vegas, Nevada. Cristo Rey St. Viator builds upon the networks history of equipping low-income students with the knowledge, character, and the skills to transform their lives. Cristo Rey graduates currently earn four-year Bachelor's degrees at more than twice the rate of high school graduates from low-income families nationwide. 88% of 2016 Cristo Rey graduates enrolled in college. 58% of CRN students are female, 61% of students are Latino, 30% are Black, and 100% are low income.

Homestead Station – City of Homestead (Homestead, FL)

\$16M NMTC Transaction – Closed 2018

Homestead Station: Downtown Homestead's Retail, Entertainment and Multimodal Center. The 250,00 square foot mixed use facility will bring entertainment, retail, dining, and a multi modal transit center to the Historic Downtown District of the City. Homestead Station will include 30,000 square feet of retail and dining space, 65,000 square feet of family entertainment center space including 10 movie theaters, 14 lanes of bowling, and 1,000 parking spaces. The City's new multimodal transit station is connecting to Miami Dade County transit infrastructure expansion projects designed to reduce commute times between the City of Miami and the City of Homestead while also increasing access to the everglades. Homestead Station will also house the City's Trolley, a free transportation service for Homestead residents and tourists.

*** The Lawson Academy - William A Lawson Institute for Peace and Prosperity (Houston, TX)**

\$10.5M NMTC Transaction – Closed 2017

The Lawson Academy, a subsidiary of the non-profit William A Lawson Institute for Peace and Prosperity, is developing a new 32,000 SF educational campus for its public middle charter school in Houston, Texas. Founded in 2002, The Lawson Academy educates low-income, minority 6th, 7th and 8th graders from Houston's 3rd Ward. The newly constructed Lawson Academy facility is comprised of 22 classrooms, science laboratories, administrative offices and class prep space, athletic fields and recreational facilities that meet LEED Silver standards. Upon completion, The Academy's enrollment will double to 300 students. The Lawson Academy's mission is to provide students with a comprehensive education in a single-gender environment based on four cornerstones: relevant curriculum; rigorous instruction, respect for self and others; and reciprocity. The Lawson Academy uses a creative academic curriculum to build student success and to develop the whole person. In addition to core subjects, The Lawson Academy also offers educational opportunities in music (music theory, choir, band, drumline, piano lessons), arts (visual art, performing arts, dance and cheerleading), technology (game design), robotics, life sciences, healthy food education, and health/physical education.



MARKETING PLAN

Introduction

TSG-Industries is an employee owned professional service firm that specializes in renewable energy construction programs, facility renewal analysis, inspections and testing service for private and public institutions. General facilities support services are a key investment indicator for our business. Our people have over 30 years of experience in architecture, construction management, engineering, and capital renewal planning. We are convinced that our service saves you money while maintaining quality efficiency. Therefore, we are committed to understanding market conditions and indicators which improve the business strategy.



1.1. Current Business Conditions

The current economic conditions are contributing to anticipated gradual growth in backlog for the short term. While a number of public and municipal entities in Gulf Coast Region passed referendums providing funding for significant capital programs.

We need to act now in order to capture new work and position us for steady growth in FY'20. Several of our initiatives are described below under the categories of regional, service and organizational strategies.



2. Key Strategies

Local presence is essential to win work. Local participations in focus groups and professional councils will provide growth and exposure. Key partnerships with highly visible economic advocacy groups provide “Facility Centers for Change” Consequently, a key part of our operational and business development model will include targeting clients in the surrounding cities and counties where we currently manage large assignments. Utilizing our existing teams and taking advantage of shared resources will allow us to be cost competitive and productive.





3. Service Strategies

Our core service will continue to be first line construction manager agent for both private and public owners and federal installations. Service delivery mechanisms will include responsibilities under a term contract, job order contracting and project management staff augmentation through T&M contracts.

Construction Management (PM) Services

The CM service has been success as “The First Step” in planning and building trust relationships within our organization. Our CM expertise and growing fast track facilities resume will create opportunities.

Moving forward, CM services will staff projects with HUBs, strategic partners and TSG leadership personnel. Teaming partners will need to have a specific expertise needed for the project or are a SWMBE firm. The goal is to maximize revenue sharing and ideally be proactive to meeting the SWMBE goals stated in the solicitation.

Our planned resources will be used to expand our CM practice by:

1. Internally market CM and JOC support services for Owners.
2. Invest in key staff resources.
3. Collaborate with sponsors.

3.1. Sustainability and Energy Conservation

Although the American Recovery and Reinvestment Act (ARRA) stresses funding for early childhood education (\$10 billion has been pledged) rather than infrastructure, a case can be made linking green construction to improved building performance. We can also note that ARRA has been greatly influenced by a report by the Center for American Progress.

We will emphasize to our clients the services we provide to develop and support an implementation plan to meet their sustainability goals, including:

- Develop the Preliminary Scope Statement, Budget and Schedule





- Manage the Owner selection process, including sustainability experience
- Coordinate with design standards and specifications integrating sustainability goals
- Review project design for adaptability and compliance with project requirements.

We are working to showcase our expertise in energy conservation and highlight it as a key competitive differentiator to enhance our core services of Program/Project/Construction Management, Facilities Assessment, and Master Planning. We will accomplish this through:

- 1) Aggressive pursuit of hallmark green projects
- 2) Professional development and strategic recruitment
- 3) Green-related publications and presentations at client organization conferences.



We have a corporate initiative which combines energy assessments with energy monitoring systems to develop conservation recommendations for our clients in order to reduce their carbon footprint and benefit from associated energy savings. Similarly to the FCA service, the PM service will provide entry-points into a variety of markets. We need to strengthen our energy evaluation and carbon footprint reduction services.

4. Marketing Strategies

We've identified various strategies to achieve this end, outlined below under the categories of *Community Outreach* and *Trade Organizations and Conferences*.

4.1. Community Outreach

We will do a better job at integrating our services more directly with the missions of prospective clients. With minimal effort, we can leverage the expertise and first line customer relations. By harnessing community outreach opportunities, we will not only strengthen our position with prospective clients, we will also build TSG reputation as an positive advocate



and a good corporate citizen. We have taken the lead on the community outreach and public information programs like NAMC, NAACP, Chamber of Commerce and other decision maker councils. We have used these opportunities to provide stakeholders with information about green schools and the facilities program as well as careers in architecture, engineering and construction. This distinction will serve as a strategic differentiator against our competition, leading to future new work.

Sustainable Initiatives– We will continue our practice of making monetary donations to existing and prospective clients, but intend to emphasize the in-kind, sweat-equity initiatives outlined above as a more effective marketing strategy.



Student internship programs – Not only do we intend to be active in our client’s classrooms, we will provide learning opportunities to our client’s students outside of the classroom. Our projects will give high school, community college, and university students valuable work experience, while elevating our brand in the educational sector. We have initiated a standard requirement for all long-term program management teams to implement an internship program.

4.2. Trade and Industry Conferences

We circulate as fellow-attendees meeting people in seminars relevant to our areas of expertise, hosted limited events, and routinely had breakfast, lunch and/or dinner outings with existing or targeted prospective clients.

TSG Industries
2200 North Loop West, Ste. 102
Houston, TX 77020
Tel.: 713-220-0211/Fax: 281-605-5037

Project Communication Matrix

Deliverable	Description	Delivery Method	Frequency	Owner	Audience
Claims Reports	Updates to Stakeholder Claims Log, Project Audits and Public Requests	Hard Copy and Electronic file	As Needed	Contracts Administrator	Project Manager OWNER
Schedule Control	Review schedule changes, schedule revisions and critical path performance	Earned Value Reports, Recovery/Acceleration plans.	Monthly	Project Manager	Field Representative OWNER
Change Reports	Project Addendum, Change Orders, Budget Revisions, Change Order Logs	Budget Re-allocations, change explanation, Expenditure Variance Report;	Weekly	Contracts Administrator	Project Manager OWNER
Presentations	Quality Assurance	Program status update on Construction Project Management Plan	Weekly	Project Manager/Lead	Owner
Project Announcements	Task reminders	Task owner schedule reminders	Daily	Project Coordinator	Project Manager Project Team
Reviews and Meetings	Team meeting	Meeting to review project status	Weekly	Project Coordinator	Project Manager Project Team
Filing and Contracts	Hard copy and electronic files	Regularly organize, scan and perform maintenance to filing system for contract documents and deliverables in compliance with Records and Retention policy.	Monthly	Project Coordinator/Lead	Project Manager Project Team

ID	Task Mode	Task Name	Duration	Start	Finish	Gantt Chart						
1	Task Mode	City of Prairie View - 13 days Temp Annex	13 days	Thu 10/15/20	Mon 11/2/20	[Gantt bars for task 1]						
2	Task Mode	Contract/NTP	3 days	Thu 10/15/20	Mon 10/19/20	[Gantt bars for task 2]						
3	Task Mode	Layout/Utility Acce	2 days	Thu 10/15/20	Fri 10/16/20	[Gantt bars for task 3]						
4	Task Mode	Submittals	1 day	Tue 10/20/20	Tue 10/20/20	[Gantt bars for task 4]						
5	Task Mode	Security Deposit	3 days	Wed 10/21/20	Fri 10/23/20	[Gantt bars for task 5]						
6	Task Mode	Site Prep/Selective	2 days	Mon 10/26/20	Tue 10/27/20	[Gantt bars for task 6]						
7	Task Mode	Electrical connecti	3 days	Tue 10/27/20	Thu 10/29/20	[Gantt bars for task 7]						
8	Task Mode	Deliver/Set-up Bldg	3 days	Wed 10/28/20	Fri 10/30/20	[Gantt bars for task 8]						
9	Task Mode	Water/Sewer connection	2 days	Thu 10/29/20	Fri 10/30/20	[Gantt bars for task 9]						
10	Task Mode	Install walkways/re	2 days	Thu 10/29/20	Fri 10/30/20	[Gantt bars for task 10]						
11	Task Mode	Relocating furnishi	2 days	Sat 10/31/20	Mon 11/2/20	[Gantt bars for task 11]						

Project: 101520 Prairie View Tern
Date: Mon 10/19/20

Task	Inactive Summary	External Tasks
Split	Manual Task	External Milestone
Milestone	Duration-only	Deadline
Summary	Manual Summary Rollup	Progress
Project Summary	Manual Summary	Manual Progress
Inactive Task	Start-only	
Inactive Milestone	Finish-only	

Task Name	Position	Start	Finish	% Complete
1. TX AMV Medical Center	119 days	Wed 8/25/19	Mon 9/30/20	50%
2. Contract	1 day	Wed 8/25/19	Wed 8/25/19	100%
3. General Conditions	16 days	Thu 8/26/19	Thu 9/7/19	85%
4. Pre-Submittals	10 days	Thu 8/26/19	Thu 9/11/19	30%
5. Kick-off Meeting	1 day	Thu 8/26/19	Thu 8/26/19	100%
6. Long Lead Items	5 days	Fri 10/11/19	Thu 10/20/19	50%
7. Vendor/Supplier Agreements	14 days	Thu 8/26/19	Thu 9/27/19	85%
8. General Requirements	36 days	Wed 10/16/19	Wed 12/4/19	84%
9. Electrical Load Analysis	21 days	Wed 10/16/19	Wed 11/13/19	100%
10. Data/IT/Recom Design	7 days	Wed 10/16/19	Thu 10/24/19	100%
11. Structural Design	14 days	Wed 10/16/19	Mon 11/4/19	100%
12. MEP Design/Main Service	21 days	Wed 10/16/19	Wed 11/11/19	100%
13. Design Review - CC	15 days	Thu 11/14/19	Wed 12/4/19	80%
14. Regulatory/Compliance	30 days	Thu 10/24/19	Wed 12/4/19	85%
15. Submittals Review	30 days	Thu 12/5/19	Wed 1/23/20	60%
16. Shop Drawings/Plans	15 days	Thu 12/5/19	Wed 12/25/19	75%
17. Fabrication/Product 15 days	15 days	Thu 12/5/19	Wed 12/25/19	75%
18. Product Delivery/MSDS	15 days	Thu 12/5/19	Wed 12/25/19	75%
19. Laboratory Equipment	15 days	Thu 12/5/19	Wed 12/25/19	75%
20. Medical Equipment	15 days	Thu 12/5/19	Wed 12/25/19	75%
21. Dental Equipment	15 days	Thu 12/5/19	Wed 12/25/19	75%
22. Hearing Equipment	15 days	Thu 12/5/19	Wed 12/25/19	75%
23. Solar Equipment	15 days	Thu 12/5/19	Wed 12/25/19	75%
24. Windows	15 days	Thu 12/5/19	Wed 12/25/19	75%
25. Government Review	15 days	Thu 12/26/19	Wed 1/23/20	0%
26. Fabrication/Delivery	38 days	Thu 12/18/20	Mon 3/9/21	0%
27. Laboratory Unit	15 days	Thu 12/18/20	Wed 1/15/21	0%
28. Medical Unit	20 days	Thu 12/18/20	Wed 1/22/21	0%
29. Site Delivery 1	2 days	Thu 12/17/20	Fri 12/18/20	0%
30. Dental Unit	30 days	Thu 12/16/20	Wed 1/28/21	0%
31. Hearing Unit	30 days	Thu 12/16/20	Wed 1/28/21	0%
32. Site Delivery 2	2 days	Thu 12/23/20	Fri 12/24/20	0%
33. Government Review	6 days	Mon 12/22/20	Mon 12/29/20	0%



Project Communication Matrix

Deliverable	Description	Delivery Method	Frequency	Owner	Audience	
Reports	Monthly Status Reports	Regular update on program issues	Hard Copy and Electronic file:	Monthly	Core Administrator	Project Manager Project Team
	RFI Reports	Regular updates on RFI response and monitoring	Sharepoint Team Report for all projects	Monthly	Contracts Administrator	Project Manager Construction Manager OWNER
	Safety Reports	Regular updates on Safety on Jobsite/Office	Incident Logs, Safety Reports, Near Misses	Weekly	Field Representative	Project Manager Construction Team
	Project/Procurement Updates	Updates to Program and Bid Calendar, notifications, legal notices and RFP's	Pre-Bid/Bid Schedule sheet, Progress Meetings, Team Meetings, Procurement Documents;	Bi-weekly	Contracts Administrator	Project Manager OWNER
	Procurement Status Report	Review the log of contractors under contract by project.	Buy-out tab, Procurement Status Log	Monthly	Project Coordinator	Project Manager Controls Manager
	Contracts (Change Orders, Amendments)	Update contracts for change in time, scope or terms and conditions	AIA documents; Owner contract documents	Weekly	Project Manager	Contract Administrator OWNER
	Cashflow Updates	Update Cash Flow projection based on projects budget and schedule	Cash Flow Projections Workbook	Monthly	Project Manager	Owner
	Budget Performance Reports	Review budget performance progress against the baseline	Project Budget Reports	Weekly	Project Manager	Contract Administrator OWNER
	Close-Out Management	Review projects progress for close-out preparation and final deliverables	Close-Out/General Conditions/Construction Specs/ checklists	Monthly	Contracts Administrator	Project Manager OWNER

Safety Record

As of 2020

Year Experience Modification Rating (EMR) Annual Man-hours

<u>2020</u>	1.0	12,610
<u>2019</u>	1.0	8,240
<u>2018</u>	1.0	10,420
<u>2017</u>	1.0	9,650

Region 4 Education Service Center

Modular Buildings, Portable Storage, and Relocatable Walkways

Solicitation Number 21-05

TAB 3

Qualifications and Experience



BUILDING CAPITAL SOLUTIONS

GENERAL ORGANIZATION

TSG Industries is a Houston based planning and construction service company that manages the successful execution of construction projects including Construction Project Management, General Contracting, Design-Build, Tenant Build-Out and Maintenance Programs for public and private asset portfolios. Also, we offer Prefabricated Modular Structures for special projects including Security, Workspaces and Health Industries. Our leaders have helped federal, public and private institutions build solutions across the nation. The primary scope of service classification is NAICS CODE: 236220 commercial and institutional construction services.

CERTIFICATIONS

- State of Texas Historically Underutilized Business (HUB) Program - Certification# RG019054
- Disadvantage Business Enterprise - Certification# 14-08-12385
- Small Business Enterprise – Certification# 14-8-12385S
- Minority Business Enterprise – Certification# 14-8-12385
- Texas Department of Insurance – Inspector – License# 1822781
- Port of Houston Authority, S/MBE
- South Central Texas Regional Certification Agency – S/M/E/AA/Business Enterprise

AREA OF EXPERTISE

- General Contracting
- Modular & Prefabricated Building Construction
- Construction Manager Agent
- Job Order Contracting
- Design-Build
- Construction Project Management - Owners Representative



BUILDING CAPITAL SOLUTIONS

2200 North Loop West, Ste. 102

Houston, TX 77018

Phone (888)586-2703 Fax (281)605-5037

www.tsg-industries.com

REFERENCES

Please provide three (3) references, preferably from school districts or other governmental entities who have used your services within the last three years. Additional references may be required. DO NOT INCLUDE TIPS EMPLOYEES AS A REFERENCE.

You may provide more than three (3) references.

Entity Name	Contact Person	VALID EMAIL IS REQUIRED	Phone
Galena Park ISD	John Moore	jmoore@galenaparkisd.com	832-386-1221
Harmony Public Schools	Mehmed Milanovic	mmilanovic@harmonytx.org	713-825-8911
Texas Southern University	Loletha Turner	Loletha.Turner@tsu.edu	713-313-7374
Prairie View A&M University	Trina Redwine-Charles	trredwine@PVAMU.EDU	936-261-1751
US Army Corps of Engineers/OISD	Pamela Monroe	pamela.l.monroe8.civ@mail.mil	703-695-3220
The Lawson Academy	Lloyd Wright	lwright16@comcast.net	713-410-4022

Mr. Patrick Mouton
Aldine Independent School District
Facilities Planning & Construction Office
1617 Lauder Road
Houston, Texas 77039

Dear Evaluators,

This Letter of Recommendation is meant to serve as an endorsement of the relationship we have established with TSG Industries. It is with pleasure that I, Mehmed Milanovic, project manager here at Harmony Public Schools, am writing to endorse the construction and project management services of TSG Industries. TSG Industries role included construction management and job order contract services.

TSG Industries provided very creditable and valuable services throughout the process. Our project had numerous challenges that were managed by TSG Industries with great expertise. This company has supported our construction renewal efforts. TSG Industries believes in our community service philosophy that students should have safe and accessible places to live and gather.

I can be reached at (713) 825-8911 if you should have questions.

Sincerely,

A handwritten signature in blue ink, appearing to read "Mehmed Milanovic", with a stylized flourish at the end.

Mehmed Milanovic
Project Manager
Harmony Public Schools

Shannon Jones
University of Houston
4800 Calhoun Road
Houston, TX 77004
RE: University of Houston

Dear Mr. Bob Menefee:

As we wrap up our bond projects, I wanted to take a moment to thank you. Mr. Menefee provided outstanding service as a construction manager for the Water Meter Abandonment Project serving Cougar Place Apartments.

Mr. Menefee was instrumental in this local HUB initiative. University of Houston was pleased to see that our project is completed within budget. As construction manager, Mr. Menefee coordinated with U of H personnel, Center Point and City of Houston departments to complete the work.

University of Houston has found Mr. Menefee to be a pro-active, positive, engaged and collaborative construction professional. He consistently exhibits willingness at all levels to listen and respond to the needs of the university and we are pleased with his performance.

Sincerely,

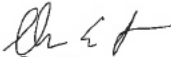

Shannon Jones
Director of Minor & Planned Projects
University of Houston

Theodore D. Sims, LEED

7040 Rook Blvd. Houston, Texas 77087
(T) (832) 660-5914 (E) tsims_101@yahoo.com

Summary of Qualifications

An executive level leader in small and large capital improvement programs for federal, state and local property asset portfolios. My strength is understanding and meeting growing Gulf Coast infrastructure and facility industry needs. My skills and experiences include planning, design, bidding, construction and close-out of multi-facet construction and maintenance programs.

- *Owner's Representative
- *CIP Asset Planning & Management
- *Construction Project Management
- *Project Controls/Quality Assurance

Experience

01/2013 – current

TSG Industries, Houston, TX
Project Director

Served as an executive liaison in charge of project oversight between procurement office, code officials, public authorities, architects, engineers, field operations, vendors and end-users for successful project completion in the following markets:

City, County Municipal: (\$1.45B)

- *City of Houston: North East Water Purification Plant Expansion, Project Control Services (2016-2017) by way of Carollo Engineers.
- *City of Houston: City-Wide Water Quality TBLL, Inspections & Testing (2017) by way of Professional Environmental Engineers, Inc.
- *Houston Airport System: SCM Warehouse Bldg., IDIQ Exterior Renovation (2017)
- *Houston Airport System: IDIQ Exterior Repair (2017-2018)
- *Brazoria County: Kidz Harbor Rehabilitation Phase II (HUD), 2017
- *Bastrop County: Animal Hospital, Interior Flood Renovation, (2018)
- *Harris Health System: Ben Taub Tower 1 Level 1, Interior Build-Out (2016-2017)
- *Houston Airport System: Hobby Airport New Satellite/Utilities Plant Bldg., CSP Roofing (2014-2015)
- *Houston Housing Authority: Historic Oaks of Parkway Villiage, IDIQ Civil Repairs (2015)
- *Metro LRT 2020 Forward: Construction Management, CM Inspections (2019) by way of Huitt-Zollars, Inc.

Federal and State (\$3.0M)

- *USDA: Houston PIS Inspection Lab, Interior Design-Build (2017-2019)
- *U.S. Army Corps of Engineers/Disaster Relief: Orangefield ISD ES/HS, Modular Temporary Campuses (2017-2018)
- *Federal Bureau of Prisons: IDIQ Building Repairs (2014-2015)
- *Texas General Land Office: Disaster Recovery Repairs (2017)
- *Texas Military Department: IDIQ Civil/Site Repairs, (2014)

K-12, Colleges & University (\$54.0M)

- *Prairie View A&M University: Administrative Bldg., IDIQ Campus Repairs (2019)
- *Texas Southern University: New Library Center, CM Project Controls (2017-2019) by way of Con-Real LP.
- *University of Houston: Main Campus, FCA Inspections (2018-2019) by way of

ISES Corporation

- *Lone Star College System: 2 campuses, IDIQ JOC Projects (2017-2020)
- *Brazosport College System: MCC Building, IDIQ JOC Projects (2017-2019)
- *Texas Southern University: New Guardhouses, Design-Build (2016-2017)
- *University of Houston, Main Campus: Site Utilities Renovation (2016)
- *University of Houston, Downtown: Main Building, Exterior Renovation (2015)
- *The Rhodes School: 2 Campuses, Design-Build (2014-2015)
- *Harmony Public Schools: Harmony Science Academy, Disaster Recovery Repairs (2015)
- *Damon ISD: Damon ES, Site Renovation (2015)
- *Galena Park ISD, 12 campuses, IDIQ Building Repairs (2013-2014), (2017-2018)
- *The Lawson Academy, New Middle School, Design-Build Manager (2016-2017)

1/2014 - 5/2015

San Jacinto College, Houston, TX
Adjunct Professor

Building Codes, Green Building,

Blueprint Reading 8/2005 - 12/2012

09/2005 – 12/2012

Parsons Corporation

CIP Planning & Controls Manager, Pasadena, CA

Served as an Planning & Controls Manager of the Commercial Buildings and Infrastructure Division for several capital improvement program-s. Led several facility asset inspections and evaluation efforts for capital budgeting baseline reviews and recommendations.

Coordinated program criteria with design professionals, consultants, facility staff and owners to define working capital bond budgetary needs.

Incorporated CMMS, PMIS and procedural guidelines and standards to manage program risks during building program phases. See examples below:

City, County and Federal (\$6.0B) by way of Parsons Corporation

- *City of San Diego: City-Wide Parks, ADA Inspections, (2009)
- *United States Postal Service: 3 States, CIP Programming, (2007)
- *United States Air Force: CONUS/OCONUS Dormitory Master Plan, CIP Programming (2006-2008)
- *National Park Services: 4 states, CIP Programming (2005-2006)

K-12, Colleges & Universities (\$3.0B) by way of 3D/International

- *Beaumont Independent School District, CIP Bond Program, Project Controls Manager (2009-2012)
- *Greenville Technical College: 4 Campuses, CIP Programming, (2008)
- *Texas A&M University: Main Campus, CIP Programming, (2008)
- *Orleans Parish/Recovery School Districts: Hurricane Katrina Recovery, CIP Programming, (2006-2007)

Education

- 2008 PEC, Houston, TX
OSHA 10

 Hour Safety

 Certification
- 2008 USGBC, Washington DC, DC
LEED AP Sustainability

 Certification
- 2005 Prairie View A&M University, Prairie View A&M University, TX
Master's Architecture

 Master's in Architecture, Community Development
- 2003 Prairie View A&M University, Prairie View, TX
Bachelor's Ag. Engineering

 Bachelor's of Science, Ag.(Civil) Engineering

References

- C.C. Lee AIA, STOA International (832) 724-7556
- Terry Smith AIA, Smith & Company (713) 330-5921
- James Harrison AIA, Harrison Kornberg Architects (832) 814-3693
- Ibn Hagler, Parsons (Estimator) (713) 874-7807
- Curtis Dumas P.E., Segma Group (832) 483-8766
- Ronnie Cotton, Segma Group (Sr. MEP Engineer) (713) 363-0270
- Brian Johnson PMP, Centerpoint Energy (Sr. Project Manager), (832) 755-9756

Service

- City of Houston, Building & Standards Commission – Board Member (2016-present)
- City of Houston, General Appeals Board – Board Member (2018-present)
- Boys & Girls Club – Contributor 2018 – present
- Society of American Military Engineers, "Planned and Unplanned Requirements" - Contributor, 2020



GREEN BUILDING CERTIFICATION INSTITUTE

HEREBY CERTIFIES THAT

Theodore Sims

HAS ACHIEVED THE DESIGNATION OF

LEED® ACCREDITED PROFESSIONAL

BY DEMONSTRATING THE KNOWLEDGE OF GREEN BUILDING PRACTICE
REQUIRED FOR SUCCESSFUL IMPLEMENTATION OF THE LEADERSHIP IN ENERGY
AND ENVIRONMENTAL DESIGN (LEED®) GREEN BUILDING RATING SYSTEM™.



Chairman

March 14, 2009

Date Issued

Peter Tompleton, President



CERTIFICATE OF LIABILITY INSURANCE

DATE (MM/DD/YYYY)
09-29-2020

THIS CERTIFICATE IS ISSUED AS A MATTER OF INFORMATION ONLY AND CONFERS NO RIGHTS UPON THE CERTIFICATE HOLDER. THIS CERTIFICATE DOES NOT AFFIRMATIVELY OR NEGATIVELY AMEND, EXTEND OR ALTER THE COVERAGE AFFORDED BY THE POLICIES BELOW. THIS CERTIFICATE OF INSURANCE DOES NOT CONSTITUTE A CONTRACT BETWEEN THE ISSUING INSURER(S), AUTHORIZED REPRESENTATIVE OR PRODUCER, AND THE CERTIFICATE HOLDER.

IMPORTANT: If the certificate holder is an ADDITIONAL INSURED, the policy(ies) must have ADDITIONAL INSURED provisions or be endorsed. If SUBROGATION IS WAIVED, subject to the terms and conditions of the policy, certain policies may require an endorsement. A statement on this certificate does not confer rights to the certificate holder in lieu of such endorsement(s).

PRODUCER 7137858900 832-553-7534 Hadley Insurance Group, LLC 9950 Westpark Dr Ste 255 Houston, TX 77063	CONTACT NAME: Hadley Insurance Group, LLC PHONE (A/C, No, Ext): 7137858900 E-MAIL ADDRESS: insurance@hadleyins.net	FAX (A/C, No): 832-553-7534
INSURED 832-660-5914 TSG Industries LLC	INSURER(S) AFFORDING COVERAGE	
	INSURER A: SCOTTSDALE INS	NAIC # 524291
	INSURER B: PROGRESSIVE CAS INS CO	24260
	INSURER C:	
	INSURER D:	
	INSURER E:	
	INSURER F:	

COVERAGES **CERTIFICATE NUMBER:** **REVISION NUMBER:**

THIS IS TO CERTIFY THAT THE POLICIES OF INSURANCE LISTED BELOW HAVE BEEN ISSUED TO THE INSURED NAMED ABOVE FOR THE POLICY PERIOD INDICATED. NOTWITHSTANDING ANY REQUIREMENT, TERM OR CONDITION OF ANY CONTRACT OR OTHER DOCUMENT WITH RESPECT TO WHICH THIS CERTIFICATE MAY BE ISSUED OR MAY PERTAIN, THE INSURANCE AFFORDED BY THE POLICIES DESCRIBED HEREIN IS SUBJECT TO ALL THE TERMS, EXCLUSIONS AND CONDITIONS OF SUCH POLICIES. LIMITS SHOWN MAY HAVE BEEN REDUCED BY PAID CLAIMS.

INSR LTR	TYPE OF INSURANCE	ADDL INSD	SUBR WVD	POLICY NUMBER	POLICY EFF (MM/DD/YYYY)	POLICY EXP (MM/DD/YYYY)	LIMITS
A	<input checked="" type="checkbox"/> COMMERCIAL GENERAL LIABILITY <input type="checkbox"/> CLAIMS-MADE <input checked="" type="checkbox"/> OCCUR GEN'L AGGREGATE LIMIT APPLIES PER: <input type="checkbox"/> POLICY <input type="checkbox"/> PRO-JECT <input type="checkbox"/> LOC OTHER:	<input checked="" type="checkbox"/>	<input checked="" type="checkbox"/>	QHCWC-D	11/19/2019	11/19/2020	EACH OCCURRENCE \$ 1,000,000 DAMAGE TO RENTED PREMISES (Ea occurrence) \$ 100,000 MED EXP (Any one person) \$ 5,000 PERSONAL & ADV INJURY \$ 1,000,000 GENERAL AGGREGATE \$ 2,000,000 PRODUCTS - COMP/OP AGG \$ 1,000,000 \$
B	<input type="checkbox"/> AUTOMOBILE LIABILITY <input type="checkbox"/> ANY AUTO <input type="checkbox"/> OWNED AUTOS ONLY <input type="checkbox"/> SCHEDULED AUTOS <input type="checkbox"/> HIRED AUTOS ONLY <input type="checkbox"/> NON-OWNED AUTOS ONLY <input type="checkbox"/> AUTOS ONLY	<input checked="" type="checkbox"/>	<input checked="" type="checkbox"/>	00971454	08/01/2020	08-01-2021	COMBINED SINGLE LIMIT (Ea accident) \$ 1,000,000 BODILY INJURY (Per person) \$ 1,000,000 BODILY INJURY (Per accident) \$ 1,000,000 PROPERTY DAMAGE (Per accident) \$ 1,000,000 \$
	<input type="checkbox"/> UMBRELLA LIAB <input type="checkbox"/> OCCUR <input type="checkbox"/> EXCESS LIAB <input type="checkbox"/> CLAIMS-MADE DED RETENTION \$						EACH OCCURRENCE \$ AGGREGATE \$ \$
C	<input type="checkbox"/> WORKERS COMPENSATION AND EMPLOYERS' LIABILITY <input type="checkbox"/> ANY PROPRIETOR/PARTNER/EXECUTIVE OFFICER/MEMBER EXCLUDED? (Mandatory in NH) If yes, describe under DESCRIPTION OF OPERATIONS below	<input type="checkbox"/>	<input checked="" type="checkbox"/>	0002053026	09/30/2020	09/30/2021	<input checked="" type="checkbox"/> PER STATUTE <input type="checkbox"/> OTH-ER 1,000,000 E.L. EACH ACCIDENT \$ 1,000,000 E.L. DISEASE - EA EMPLOYEE \$ 1,000,000 E.L. DISEASE - POLICY LIMIT \$ 1,000,000

DESCRIPTION OF OPERATIONS / LOCATIONS / VEHICLES (ACORD 101, Additional Remarks Schedule, may be attached if more space is required)
Contract number DFD-2020-00013438 TEMP HOUSING AND DOME STRUCTURES

CERTIFICATE HOLDER Phone : Fax:	CANCELLATION
Dallas Fire Department: attn Adenia Clark 1500 Marilla Street 3FN Dallas, TX 75201	SHOULD ANY OF THE ABOVE DESCRIBED POLICIES BE CANCELLED BEFORE THE EXPIRATION DATE THEREOF, NOTICE WILL BE DELIVERED IN ACCORDANCE WITH THE POLICY PROVISIONS.
	AUTHORIZED REPRESENTATIVE 

© 1988-2015 ACORD CORPORATION. All rights reserved.



BUILDING CAPITAL SOLUTIONS

2200 North Loop West, Ste. 102 • Houston • Texas • 77054

Mobile: (832) 660-5914

www.tsg-industries.com

tsims@tsg-industries.com

4.0 WARRANTY (1 Year)

TSG Industries building warranty on a renovated construction is 1-year which includes all improved surfaces and equipment. In addition to the standard manufacturer's 1-year warranty, TSG typically provides a 1-year labor and 1-year parts on the electrical and plumbing system. The electrical plumbing warranty starts from the date the building occupancy at the site and covers any plumbing issues on the improved labs with the scope.

4.1 MATERIALS AND WORKMANSHIP WARRANTY.

TSG Industries (Contractor) expressly warrants that all items, materials, and work furnished through vendors, suppliers and subcontractor under this contract will conform to specifications, drawings, samples, or other description referred to herein or given by Owner to Contractor. All the work shall be performed with workmanship consistent with sound construction practice, and all items and materials shall be new, free from defects, of merchantable quality, and fit for the purposes intended. Contractor shall install or apply all materials, whether furnished by Contractor or Subcontractor, in strict accordance with installation or application instructions and procedures set forth by the material supplier.

4.2 WARRANTY REMEDY

4.2.1 Should there be defects, errors, or omissions in, or breach of, any warranty of Contractor concerning items, materials, or workmanship, Subcontractor, without cost to Owner, shall promptly correct, repair, or replace the materials or workmanship in whatever manner necessary so that all the requirements of this contract and the obligations of Contractor under Article 4 are satisfactorily fulfilled. If Subcontractor fails after reasonable notice to proceed promptly with the correction, repair, or replacement of any defective items, materials, or workmanship, Contractor may replace or repair such items or materials, correct such workmanship, and charge the cost thereof to Subcontractor and/or may terminate this Subcontract for default.

4.3 WARRANTY BENEFICIARIES.

All of Contractor's warranties and all warranty remedies hereunder shall be for the benefit of, and shall be enforceable by the Owner. Those warranties and remedies obtained by vendors and suppliers shall also be made enforceable by the Owner.

Sincerely,

A handwritten signature in black ink, appearing to read 'T. Sims', written over a light blue horizontal line.

Theodore D. Sims, LEED AP
General Manager



TSG Industries
2200 North Loop West, Suite 102
Houston, Texas 77018
Office: (713) 218-0211
Fax: (281) 605-5037
www.tsg-industries.com

UNITED STATES CORPS OF ENGINEERS



Civil Engineer:
Kenneth Heisner, PE

Location:
Orange, Texas

Project Duration:
November 2017-July
2018

Contract Type:
Lump Sum

Services Provided:
Design-Build Modular
Campus; Hurricane
Harvey Recovery

Value:
\$2,550,000

Client Contact:
Shamekia Chapman
Deputy of Small Business
Shamekia.M.Chapman@usace.army.mil
2000 Fort Point Road
Galveston TX 77550-1229
T: (409)-766-3006

Project Description

As a result of Hurricane Harvey in August 2018, we are actively involved in a partnership with the United States Army Corps' of Engineers. The design-build project develops 15,580 square feet of new modular buildings at Orangefield Elementary and High School. The new additions consist of (16) classrooms, (1) restroom, (1) office and (1) theater buildings with associated site development. The scope of work included earth work, concrete aggregate, water utilities, electrical, carpentry, modular buildings, elevated decks/canopies, and fire code compliance.



Key Projects:

1. New Elementary Campus, of (16) classrooms, (1) restroom, (1) office buildings.
2. New High School Campus, (1) theater buildings.

Pacesetter Live



EMERGENCY OPERATIONS, GALVESTON DISTRICT

ORANGEFIELD ELEMENTARY SCHOOL RECEIVES PORTABLE BUILDINGS

JULY 17, 2018 | RTOWNSEND



Portable buildings at Orangefield Elementary School in Orangefield, Texas are almost ready for the 2018 school year.

Heavy rains from Hurricane flooded the elementary school. The portable buildings will be



2.2 Space/Logistics Experience



ME – 004 Relocation Campus – Investment included a 23 building temporary campus which included offices, learning space and cafeteria. The campus allowed for optimum use by providing swing space during onsite construction for three schools.

Design Cost: \$40,000

Construction Cost: \$4,189,589

Architect: Long Architects

Project Oversight Committee:

Judge Paul Brown, Co-Chair of the Oversight Committee

"Keep the money local – I'm proud to say the project team achieved just that!"

Phone Number: (409)-842-3272

NAACP Beaumont

3280 Washington Blvd.

Beaumont, Texas 77705

Dr. Carroll Thomas, Superintendent of Schools

"Pro-active, engaged and collaborative" ..."
avoiding disruption"

Phone Number: (409)-838-7252

Retired

Spring, Texas



TSG Industries
2200 North Loop West, Suite 102
Houston, Texas 77018
Office: (713) 218-0211
Fax: (281) 608-5037
www.tsg-industries.com

CITY OF PRAIRIE VIEW

Construction Manager:
Ted Sims, LEED AP

Location:
Prairie View, Texas

Project Duration:
October 2020-Ongoing

Contract Type:
Lump Sum

Services Provided:
Construction Manager
Agent

Value:
\$207,000

Client Contact:
Judge Shyletha Simmons
Presiding Judge
salexander@prairieviewtexas.gov

44500 US 290-BUS
Prairie View, TX 77446
T: 346-254-9241



Project Description

We are actively involved in City of Prairie View administration expansion due to Cares Act provisions for police department and municipal court office annex. The scope of work includes construction of new site utilities, building foundation, modular buildings, common walkways.

Key Projects:

- 1.) Hurricane Harvey-Disaster Recovery relief repairs, main building, administrative swing space during construction.
- 2.) Police Department – Cares Act expansion for administrative support facilities.



TSG Industries
2200 North Loop West, Suite 102
Houston, Texas 77018
Office: (713) 218-0211
Fax: (281) 605-5037
www.tsg-industries.com

BASTROP COUNTY ANIMAL HOSPITAL

Construction Manager:

Ted Sims, LEED AP

Location:

Bastrop County, Texas

Project Duration:

November 2018-
January 2019

Contract Type:

Job Order Contract

Services Provided:

Construction services

Value:

\$82,000

Client Contact:

Shawn Harris

Facility Director

shawn.harris@co.bastrop.tx.us

804 Pecan Street

Bastrop, TX 78602

T (512) 581-1847



Project Description

We provided flood repair construction services for Bastrop County, Animal Hospital Renovation. The project location was completed in Bastrop, Texas. The intent of work was to provide temporary modular operations during the construction phase. The scope included select demolition, high traffic finishes shelter common areas including central station, lobby, restrooms, breakroom, kennel room, operating room, main corridors, receiving room, and wash room. The work package included new high traffic flooring, wall finishes, doors, plumbing fixtures, millwork and plumbing.





TSG Industries
2200 North Loop West, Suite 102
Houston, Texas 77018
Office: (713) 218-0211
Fax: (281) 605-5037
www.tsg-industries.com

THE RHODES SCHOOL

Construction Manager:
Ted Sims, LEED AP

Location:
Houston, Texas



Project Duration:
April 2014-Ongoing

Contract Type:
Lump Sum

Services Provided:
Construction
Management Agent

Value:
\$250,000

Client Contact:
Brandon Miller
Director of Facilities
bmiller@rhodesschool.org

12818 Tidwell Rd.
Houston, TX 77004
T: 281-608-9021

Project Description

We are actively involved in construction project management services for 38,640 square feet and (17) acres at three (3) campuses of The Rhodes School. We used **AutoCAD, Microsoft Project and Microsoft Office** to help design and construction contract administration. The scopes of services include design and construction of new site utilities for a 10-acre site. The site will accommodate 19 buildings. The scope of work include earth work, concrete, utilities, electrical, carpentry, modular buildings, canopies, owner furnished equipment and fire code compliance. The campus upgrades include administrative offices, easements, parking lots, sidewalks, cafeteria, classrooms, libraries, storage rooms, and recreational area. The recycle waste record indicated 500 lbs. of wood and 1,000 lbs. of non-ferrous metals recovered from the project.

Key Projects:

- 1.) New Uvalde Campus, Pre-Construction Services – Program and Design Earthwork, Storm Drainage Water Detention Structures, Domestic Water, Sanitary Sewer, Easements, Fire Code Compliance, Right-Of-Way, Parking and Paving Plans.
- 2.) New Uvalde Campus, Construction Management Services – Direct and Manage Construction of Earthwork, Site Utilities, Earthwork, C-I-P Concrete, Site Improvements, Parking and Paving Plans.
- 3.) Robert E. Lee Campus, Pre-Construction Services – Program and Design Earthwork, Storm Drainage Water Detention Structures, Parking and Paving, Fire Code Compliance Project.
- 4.) Robert E. Lee Campus, Construction Management Services – Direct and Manage Construction of Earthwork, Storm Drainage Water Detention Structures, Parking and Paving, Fire Code Compliance Project.



TSG Industries
2200 North Loop West, Suite 102
Houston, Texas 77018
Office: (713) 218-0211
Fax: (281) 605-5037
www.tsg-industries.com

THE LAWSON ACADEMY



PM/CM Function:
Ted Sims, LEED AP

Client:
William A. Lawson Institute
Peace & Prosperity

Location:
5220 Scott Street,
Houston, Texas 77004

Project Duration:
April 2016- August 2017

Contract Type:
Lump Sum

Services Provided:
- Owner Representative

- **Project Value:**
\$11,250,000

- **Owners Representative:**
- Lloyd Wright
- T: (713) 410-4022

Project Description



LAWSON ACADEMY

The design-build project consists of new development of an existing 5.4-acre site recently obtained through acquisition. The design currently proposes 16 classrooms within 32,000 square feet. The common areas consists of administration, cafeteria and outdoor recreation space. The school will provide education for approximately 300 students in the middle school grades. Special provision pending for science laboratory, math laboratory, technology center and fine arts center. The total project budget is \$9,335,296.

Notice to Proceed: April 21, 2016; **Completion:** November 31, 2017

- 1.) Construction Project Manager
- 2.) Contract Administration
- 3.) Bidding & Contracts
- 4.) Project Schedule Analysis
- 5.) Construction Cost Analyst



TSG Industries
2200 North Loop West, Suite 102
Houston, Texas 77018
Office: (713) 218-0211
Fax: (281) 605-5037
www.tsg-industries.com

Texas Southern University



**Project
Manager/Supervisor:**
Bob Menefee

Location

- 3100 Cleburne
- Houston, Texas 77004

Project Duration:

May 2015 through May
2016

Services Provided:

- Job Order Contracting
- Value: To date:\$
90,000.00
- Indefinite Delivery
Indefinite Quantity

Owners

- **Representative:**
• Dan Williams
- Project Manager;
Facilities Planning and
Management
- 3100 Cleburne
- Houston, Texas 77004
- 713-313-1804

Project Description

We are actively involved in job order contracting services for Texas Southern University at their main location. The job order contracts so far has included the repair of plumbing systems, insulation of existing piping, installation of additional plumbing, and electrical improvements. TSG provides qualified labor augmentation to supplement the existing staff. We provide proposals for building upgrades including restrooms, hallways/corridors, mechanical rooms, administrative offices, libraries, main atriums exterior improvements and roofing. The projects have all been quantified separately and not necessarily by square footage, but by individual job orders.

Notice to proceed: This is an annual contract: Began May 2015.

Key Projects:

- 1.) Main Water valve replacement
- 2.) Plumbing Insulation
- 3.) Underground water main repairs
- 4.) Electrical improvements
- 5.) Design-Build New (4) Guardhouses

Region 4 Education Service Center

Modular Buildings, Portable Storage, and Relocatable Walkways

Solicitation Number 21-05

TAB 4

Value Add



Sustainability and Waste Management Plan



TSG's Project Execution involves seamlessly integrating sustainability into the everyday practices of the project team. This can be accomplished by recognizing that sustainability is a necessary component of the project, understanding how sustainability applies to the technical deliverables of the project, and following through with this **Sustainability Plan**.

There are four key areas for sustainability implementation in every project:

- Sustainability Integration and Management
- Required Sustainability Elements.
- Project Specific Sustainability Elements
- Client Requested/Optional Sustainability Elements

SUSTAINABILITY INTEGRATION & MANAGEMENT

GOALS AND OBJECTIVES

The goals for sustainability within projects are integrated throughout the design and construction of efficient, sustainable building systems. The value is achieved through consideration for greenhouse gas emissions, diverting construction waste from landfills through recycling and reuse, and continually evaluating sustainable alternatives throughout the construction phase.

Our mission is to promote conservation of natural resources and economic solutions to construction and maintenance issues through sustainable alternatives.

The project location has unique property conditions considering the surrounding development underway. Wheeler Avenue. Our two sustainable goals during the project are reducing the carbon footprint and **reuse natural site resources** which positively impact our environment. We commit to working with the design team to find unique way to build a **sustainable** and **energy efficient** campus.

***See the Construction Waste Record attached to record recyclables for LEED project points.**

PROJECT NAME _____

CONTRACT NO. _____

CONTRACTOR TSG Industries

LOCATION _____

DATE _____

HOURLY LABOR RATE WORKSHEET

(Reference 'Change Orders' in Contract General Conditions. Certified payrolls required for all workers on Project. Contractor shall enter data into all fields highlighted in yellow; for fields highlighted in blue, data will automatically populate.)

TRADE: _____

CLASSIFICATION: _____

Labor

Item	Rate Per \$100	Prevailing Wage Rate			Notes
		Regular Time	Overtime	Double Time	
Base Labor Rate		\$ 12.50	\$ 18.75	\$ 25.00	Use certified payroll to verify.
Fringe Benefits:					
Pension ¹			-	-	
Health/Welfare ¹		1.40	1.40	1.40	
Training/Certification ¹		4.15	4.15	4.15	
Vacation/Holiday ¹		1.50	1.50	1.50	
Other (Lodging)			-	-	
Fringe Benefits Subtotal		\$ 7.05	\$ 7.05	\$ 7.05	
Total PW Hourly Rate		\$ 19.55	\$ 25.80	\$ 32.05	= Base Labor Rate + Benefits Paid + Benefits Provided
Benefits Paid		\$ 5.55	\$ 5.55	\$ 5.55	
Total Paid Hourly Rate		\$ 18.05	\$ 24.30	\$ 30.55	= Base Labor Rate + Benefits Paid
Burden: Taxes & Insurance ²					
FICA	0.1033	1.87	2.51	3.16	
Medicare	0.0116	0.21	0.28	0.35	
Federal Unemployment	0.0490	0.88	1.19	1.50	
Texas Unemployment	0.0360	0.65	0.87	1.10	Maximum - 0.062.
Workers Compensation ¹	0.025	0.45	0.45	0.45	
Other ¹		-	-	-	
Other ¹		-	-	-	
Burden Subtotal		\$ 4.06	\$ 5.31	\$ 6.56	
Contractor Liability Insurance		N/A	N/A	N/A	
Small Tools		N/A	N/A	N/A	
Other (warranty, record drawings, payment bonds, performance bonds, etc.)		N/A	N/A	N/A	
TOTAL HOURLY RATE (Total Hourly Rate + Burden)		\$ 23.61	\$ 31.11	\$ 38.61	= Amount Contractor paid to employee

Benefit Paid	Benefit Provided
(put X in appropriate box)	
	X
X	
X	
	X

Note: For change order work, mark-ups for overhead and profit shall be applied to the above rates (these rates are subject to audit) in accordance with the provisions of CGCs, under 'Change Orders'. Mark-up rates for utility repair work shall be adjusted in accordance with the CGCs, under 'Contractor's Responsibility for the Work', subsection 'e-Utilities'.

¹ Costs for Overtime and Double Time are same as for Regular Time.

² Taxes & Insurance apply to Total Paid Hourly Rate which includes Base Labor Rate plus benefits paid in cash.

By signing below, the submitter certifies and declares under penalty of perjury under the laws of the State of Texas that the foregoing is true and correct.

Rates certified by: _____ Company Name: _____
(print name)

Signature: _____

PROJECT NAME _____
 CONTRACTOR TSG Industries

CONTRACT NO. _____
 LOCATION _____
 DATE _____

HOURLY LABOR RATE WORKSHEET

(Reference 'Change Orders' in Contract General Conditions. Certified payrolls required for all workers on Project. Contractor shall enter data into all fields highlighted in yellow; for fields highlighted in blue, data will automatically populate.)

TRADE: _____

CLASSIFICATION: Quality Control Manager

Item	Rate Per \$100	Prevailing Wage Rate			Notes
		Regular Time	Overtime	Double Time	
Base Labor Rate		\$ 47.50	\$ 71.25	\$ 95.00	Use certified payroll to verify.
Fringe Benefits:					
Pension ¹		5.65	5.65	5.65	
Health/Welfare ¹		1.40	1.40	1.40	
Training/Certification ¹		0.75	0.75	0.75	
Vacation/Holiday ¹		1.50	1.50	1.50	
Other (Lodging)		11.68	11.68	11.68	
Fringe Benefits Subtotal		\$ 20.98	\$ 20.98	\$ 20.98	
Total PW Hourly Rate		\$ 68.48	\$ 92.23	\$ 115.98	= Base Labor Rate + Benefits Paid + Benefits Provided
Benefits Paid		\$ 2.15	\$ 2.15	\$ 2.15	
Total Paid Hourly Rate		\$ 49.65	\$ 73.40	\$ 97.15	= Base Labor Rate + Benefits Paid
Burden: Taxes & Insurance ²					
FICA	0.1033	5.13	7.58	10.04	
Medicare	0.0116	0.58	0.85	1.13	
Federal Unemployment	0.0490	2.43	3.60	4.76	
Texas Unemployment	0.0360	1.79	2.64	3.50	Maximum - 0.062.
Workers Compensation ¹	0.025	1.24	1.24	1.24	
Other ¹		-	-	-	
Other ¹		-	-	-	
Burden Subtotal		\$ 11.17	\$ 15.92	\$ 20.67	
Contractor Liability Insurance		N/A	N/A	N/A	
Small Tools		N/A	N/A	N/A	
Other (warranty, record drawings, payment bonds, performance bonds, etc.)		N/A	N/A	N/A	
TOTAL HOURLY RATE (Total Hourly Rate + Burden)		\$ 79.65	\$ 108.15	\$ 136.65	= Amount Contractor paid to employee

Note: For change order work, mark-ups for overhead and profit shall be applied to the above rates (these rates are subject to audit) in accordance with the provisions of CGCs, under 'Change Orders'. Mark-up rates for utility repair work shall be adjusted in accordance with the CGCs, under 'Contractor's Responsibility for the Work', subsection 'e-Utilities'.

¹ Costs for Overtime and Double Time are same as for Regular Time.

² Taxes & Insurance apply to Total Paid Hourly Rate which includes Base Labor Rate plus benefits paid in cash.

By signing below, the submitter certifies and declares under penalty of perjury under the laws of the State of Texas that the foregoing is true and correct.

Rates certified by: _____ Company Name: _____
 (print name)

Signature: _____

Region 4 Education Service Center

Modular Buildings, Portable Storage, and Relocatable Walkways

Solicitation Number 21-05

TAB 5

Signature Forms

(c) Uses net proceeds to maintain, improve, or expand the operations of the organization.

Obligations means, when used in connection with a non-Federal entity's utilization of funds under a Federal award, orders placed for property and services, contracts and subawards made, and similar transactions during a given period that require payment by the non-Federal entity during the same or a future period.

Pass-through entity means a non-Federal entity that provides a subaward to a subrecipient to carry out part of a Federal program.

Recipient means a non-Federal entity that receives a Federal award directly from a Federal awarding agency to carry out an activity under a Federal program. The term recipient does not include subrecipients.

Simplified acquisition threshold means the dollar amount below which a non-Federal entity may purchase property or services using small purchase methods. Non-Federal entities adopt small purchase procedures in order to expedite the purchase of items costing less than the simplified acquisition threshold. The simplified acquisition threshold is set by the Federal Acquisition Regulation at 48 CFR Subpart 2.1 (Definitions) and in accordance with 41 U.S.C. 1908. As of the publication of this part, the simplified acquisition threshold is \$250,000, but this threshold is periodically adjusted for inflation. (Also see definition of § 200.67 Micro-purchase.)

Subaward means an award provided by a pass-through entity to a subrecipient for the subrecipient to carry out part of a Federal award received by the pass-through entity. It does not include payments to a contractor or payments to an individual that is a beneficiary of a Federal program. A subaward may be provided through any form of legal agreement, including an agreement that the pass-through entity considers a contract.

Subrecipient means a non-Federal entity that receives a subaward from a pass-through entity to carry out part of a Federal program; but does not include an individual that is a beneficiary of such program. A subrecipient may also be a recipient of other Federal awards directly from a Federal awarding agency.

Termination means the ending of a Federal award, in whole or in part at any time prior to the planned end of period of performance.

The following certifications and provisions may be required and apply when Participating Agency expends federal funds for any purchase resulting from this procurement process. Pursuant to 2 C.F.R. § 200.326, all contracts, including small purchases, awarded by the Participating Agency and the Participating Agency's subcontractors shall contain the procurement provisions of Appendix II to Part 200, as applicable.

APPENDIX II TO 2 CFR PART 200

(A) Contracts for more than the simplified acquisition threshold currently set at \$250,000, which is the inflation adjusted amount determined by the Civilian Agency Acquisition Council and the Defense Acquisition Regulations Council (Councils) as authorized by 41 U.S.C. 1908, must address administrative, contractual, or legal remedies in instances where contractors violate or breach contract terms, and provide for such sanctions and penalties as appropriate.

Pursuant to Federal Rule (A) above, when a Participating Agency expends federal funds, the Participating Agency reserves all rights and privileges under the applicable laws and regulations with respect to this procurement in the event of breach of contract by either party.

Does offeror agree? YES T.S Initials of Authorized Representative of offeror

(B) Termination for cause and for convenience by the grantee or subgrantee including the manner by which it will be effected and the basis for settlement. (All contracts in excess of \$10,000)

Pursuant to Federal Rule (B) above, when a Participating Agency expends federal funds, the Participating Agency reserves the right to immediately terminate any agreement in excess of \$10,000 resulting from this procurement process in the event of a breach or default of the agreement by Offeror as detailed in the terms of the contract.

Does offeror agree? YES T.S Initials of Authorized Representative of offeror

(C) Equal Employment Opportunity. Except as otherwise provided under 41 CFR Part 60, all contracts that meet the definition of "federally assisted construction contract" in 41 CFR Part 60-1.3 must include the equal opportunity clause provided under 41 CFR 60-1.4(b), in accordance with Executive Order 11246, "Equal Employment Opportunity" (30 CFR 12319, 12935, 3 CFR Part, 1964-1965 Comp., p. 339), as amended by Executive Order 11375, "Amending Executive Order 11246 Relating to Equal Employment Opportunity," and implementing regulations at 41 CFR part 60, "Office of Federal Contract Compliance Programs, Equal Employment Opportunity, Department of Labor."

Pursuant to Federal Rule (C) above, when a Participating Agency expends federal funds on any federally assisted construction contract, the equal opportunity clause is incorporated by reference herein.

Does offeror agree to abide by the above? YES T.S Initials of Authorized Representative of offeror

(D) Davis-Bacon Act, as amended (40 U.S.C. 3141-3148). When required by Federal program legislation, all prime construction contracts in excess of \$2,000 awarded by non-Federal entities must include a provision for compliance with the Davis-Bacon Act (40 U.S.C. 3141-3144, and 3146-3148) as supplemented by Department of Labor regulations (29 CFR Part 5, "Labor Standards Provisions Applicable to Contracts Covering Federally Financed and Assisted Construction"). In accordance with the statute, contractors must be required to pay wages to laborers and mechanics at a rate not less than the prevailing wages specified in a wage determination made by the Secretary of Labor. In addition, contractors must be required to pay wages not less than once a week. The non-Federal entity must place a copy of the current prevailing wage determination issued by the Department of Labor in each solicitation. The decision to award a contract or subcontract must be conditioned upon the acceptance of the wage determination. The non-Federal entity must report all suspected or reported violations to the Federal awarding agency. The contracts must also include a provision for compliance with the Copeland "Anti-Kickback" Act (40 U.S.C. 3145), as supplemented by Department of Labor regulations (29 CFR Part 3, "Contractors and Subcontractors on Public Building or Public Work Financed in Whole or in Part by Loans or Grants from the United States"). The Act provides that each contractor or subrecipient must be prohibited from inducing, by any means, any person employed in the construction, completion, or repair of public work, to give up any part of the compensation to which he or she is otherwise entitled. The non-Federal entity must report all suspected or reported violations to the Federal awarding agency.

Pursuant to Federal Rule (D) above, when a Participating Agency expends federal funds during the term of an award for all contracts and subgrants for construction or repair, offeror will be in compliance with all applicable Davis-Bacon Act provisions.

Does offeror agree? YES T.S Initials of Authorized Representative of offeror

(E) Contract Work Hours and Safety Standards Act (40 U.S.C. 3701-3708). Where applicable, all contracts awarded by the non-Federal entity in excess of \$100,000 that involve the employment of mechanics or laborers must include a provision for compliance with 40 U.S.C. 3702 and 3704, as supplemented by Department of Labor regulations (29 CFR Part 5). Under 40 U.S.C. 3702 of the Act, each contractor must be required to compute the wages of every mechanic and laborer on the basis of a standard work week of 40 hours. Work in excess of the standard work week is permissible provided that the worker is compensated at a rate of not less than one and a half times the basic rate of pay for all hours worked in excess of 40 hours in the work week. The requirements of 40 U.S.C. 3704 are applicable to construction work and provide that no laborer or mechanic must be required to work in surroundings or under working conditions which are unsanitary, hazardous or dangerous. These requirements do not apply to the purchases of supplies or materials or articles ordinarily available on the open market, or contracts for transportation or transmission of intelligence.

Pursuant to Federal Rule (E) above, when a Participating Agency expends federal funds, offeror certifies that offeror will be in compliance with all applicable provisions of the Contract Work Hours and Safety Standards Act during the term of an award for all contracts by Participating Agency resulting from this procurement process.

Does offeror agree? YES T.S Initials of Authorized Representative of offeror

(F) Rights to Inventions Made Under a Contract or Agreement. If the Federal award meets the definition of "funding agreement" under 37 CFR §401.2 (a) and the recipient or subrecipient wishes to enter into a contract with a small business firm or nonprofit organization regarding the substitution of parties, assignment or performance of experimental, developmental, or research work under that "funding agreement," the recipient or subrecipient must comply with the requirements of 37 CFR Part 401, "Rights to Inventions Made by Nonprofit Organizations and Small Business Firms Under Government Grants, Contracts and Cooperative Agreements," and any implementing regulations issued by the awarding agency.

Pursuant to Federal Rule (F) above, when federal funds are expended by Participating Agency, the offeror certifies that during the term of an award for all contracts by Participating Agency resulting from this procurement process, the offeror agrees to comply with all applicable requirements as referenced in Federal Rule (F) above.

Does offeror agree? YES T.S Initials of Authorized Representative of offeror

(G) Clean Air Act (42 U.S.C. 7401-7671q.) and the Federal Water Pollution Control Act (33 U.S.C. 1251-1387), as amended— Contracts and subgrants of amounts in excess of \$150,000 must contain a provision that requires the non-Federal award to agree to comply with all applicable standards, orders or regulations issued pursuant to the Clean Air Act (42 U.S.C. 7401-7671q) and the Federal Water Pollution Control Act as amended (33 U.S.C. 1251- 1387). Violations must be reported to the Federal awarding agency and the Regional Office of the Environmental Protection Agency (EPA)

Does offeror agree? YES T.S Initials of Authorized Representative of offeror

CERTIFICATION OF COMPLIANCE WITH BUY AMERICA PROVISIONS

To the extent purchases are made with Federal Highway Administration, Federal Railroad Administration, or Federal Transit Administration funds, offeror certifies that its products comply with all applicable provisions of the Buy America Act and agrees to provide such certification or applicable waiver with respect to specific products to any Participating Agency upon request. Purchases made in accordance with the Buy America Act must still follow the applicable procurement rules calling for free and open competition.

Does offeror agree? YES T.S Initials of Authorized Representative of offeror

CERTIFICATION OF ACCESS TO RECORDS – 2 C.F.R. § 200.336

Offeror agrees that the Inspector General of the Agency or any of their duly authorized representatives shall have access to any documents, papers, or other records of offeror that are pertinent to offeror's discharge of its obligations under the Contract for the purpose of making audits, examinations, excerpts, and transcriptions. The right also includes timely and reasonable access to offeror's personnel for the purpose of interview and discussion relating to such documents.

Does offeror agree? YES T.S Initials of Authorized Representative of offeror

CERTIFICATION OF APPLICABILITY TO SUBCONTRACTORS

Offeror agrees that all contracts it awards pursuant to the Contract shall be bound by the foregoing terms and conditions.

Does offeror agree? YES T.S Initials of Authorized Representative of offeror

Offeror agrees to comply with all federal, state, and local laws, rules, regulations and ordinances, as applicable. It is further acknowledged that offeror certifies compliance with all provisions, laws, acts, regulations, etc. as specifically noted above.

Offeror's Name: TSG Industries

Address, City, State, and Zip Code: 7040 Rook Blvd.

Phone Number: 1-888-586-2703 Fax Number: _____

Printed Name and Title of Authorized Representative: Theodore Sims, Managing Principal

Email Address: tsims@tsg-industries.com

Signature of Authorized Representative:  Date: February 8, 2021

3. The undersigned shall require that the language of this certification be included in the award documents for all subawards at all tiers (including subcontracts, subgrants, and contracts under grants, loans, and cooperative agreements) and that all subrecipients shall certify and disclose accordingly.

This certification is a material representation of fact upon which reliance was placed when this transaction was made or entered into. Submission of this certification is a prerequisite for making or entering into this transaction imposed by 31, U.S.C. § 1352 (as amended by the Lobbying Disclosure Act of 1995). Any person who fails to file the required certification shall be subject to a civil penalty of not less than \$10,000 and not more than \$100,000 for each such failure.

The Contractor, TSG Industries, certifies or affirms the truthfulness and accuracy of each statement of its certification and disclosure, if any. In addition, the Contractor understands and agrees that the provisions of 31 U.S.C. § 3801 *et seq.*, apply to this certification and disclosure, if any.



Signature of Contractor's Authorized Official

Theodore Sims, Managing Partner

Name and Title of Contractor's Authorized Official

February 8, 2021

Date"

10. Procurement of Recovered Materials.

- a. Applicability: This requirement applies to all FEMA grant and cooperative agreement programs.
- b. A non-Federal entity that is a state agency or agency of a political subdivision of a state and its contractors must comply with Section 6002 of the Solid Waste Disposal Act, Pub. L. No. 89-272 (1965) (codified as amended by the Resource Conservation and Recovery Act at 42 U.S.C. § 6962). See 2 C.F.R. Part 200, Appendix II, ¶ J; 2 C.F.R. § 200.322; PDAT Supplement, Chapter V, ¶ 7.
- c. The requirements of Section 6002 include procuring only items designated in guidelines of the EPA at 40 C.F.R. Part 247 that contain the highest percentage of recovered materials practicable, consistent with maintaining a satisfactory level of competition, where the purchase price of the item exceeds \$10,000 or the value of the quantity acquired by the preceding fiscal year exceeded \$10,000; procuring solid waste management services in a manner that maximizes energy and resource recovery; and establishing an affirmative procurement program for procurement of recovered materials identified in the EPA guidelines.
- d. The following provides the clause that a state agency or agency of a political subdivision of a state and its contractors can include in contracts meeting the above contract thresholds:

"(1) In the performance of this contract, the Contractor shall make maximum use of products containing recovered materials that are EPA- designated items unless the product cannot be acquired—

- (i) Competitively within a timeframe providing for compliance with the contract performance schedule;

3.0, ¶ XXV (2013).

- b. The following provides a contract clause regarding DHS Seal, Logo, and Flags: "The contractor shall not use the DHS seal(s), logos, crests, or reproductions of flags or likenesses of DHS agency officials without specific FEMA pre- approval."

13. Compliance with Federal Law, Regulations, and Executive Orders.

- a. All non-Federal entities must place into their contracts an acknowledgement that FEMA financial assistance will be used to fund the contract along with the requirement that the contractor will comply with all applicable federal law, regulations, executive orders, and FEMA policies, procedures, and directives.
- b. The following provides a contract clause regarding Compliance with Federal Law, Regulations, and Executive Orders: "This is an acknowledgement that FEMA financial assistance will be used to fund the contract only. The contractor will comply will all applicable federal law, regulations, executive orders, FEMA policies, procedures, and directives."

14. No Obligation by Federal Government.

- a. The non-Federal entity must include a provision in its contract that states that the Federal Government is not a party to the contract and is not subject to any obligations or liabilities to the non-Federal entity, contractor, or any other party pertaining to any matter resulting from the contract.
- b. The following provides a contract clause regarding no obligation by the Federal Government: "The Federal Government is not a party to this contract and is not subject to any obligations or liabilities to the non-Federal entity, contractor, or any other party pertaining to any matter resulting from the contract."

15. Program Fraud and False or Fraudulent Statements or Related Acts.

- a. The non-Federal entity must include a provision in its contract that the contractor acknowledges that 31 U.S.C. Chap. 38 (Administrative Remedies for False Claims and Statements) applies to its actions pertaining to the contract.
- b. The following provides a contract clause regarding Fraud and False or Fraudulent or Related Acts: "The contractor acknowledges that 31 U.S.C. Chap. 38 (Administrative Remedies for False Claims and Statements) applies to the contractor's actions pertaining to this contract."

Additional contract clauses per 2 C.F.R. § 200.325

For applicable construction/reconstruction/renovation and related services: A payment and performance bond are both required for 100 percent of the contract price. A "performance bond" is one executed in connection with a contract to secure fulfillment of all the contractor's obligations under such contract. A "payment bond" is one executed in connection with a contract to assure payment as required by law of all persons supplying labor and material in the execution of the work provided in the contract.

Offeror agrees to comply with all terms and conditions outlined in the FEMA Special Conditions section of this solicitation.

Offeror's Name: TSG Industries

7040 Rook Blvd., Houston, Texas 77087

Address, City, State, and Zip Code:

Phone Number: 1-888-586-2703 Fax Number: _____

Printed Name and Title of Authorized
Representative: Theodore Sims, Managing Partner

Email Address: tsims@tsg-industries.com

Signature of Authorized Representative: _____



February 8, 2021 Date: _____

Part III DISCLOSURE OF 10% OR GREATER OWNERSHIP IN THE STOCKHOLDERS, PARTNERS OR LLC MEMBERS LISTED IN PART II

If a bidder has a direct or indirect parent entity which is publicly traded, and any person holds a 10 percent or greater beneficial interest in the publicly traded parent entity as of the last annual federal Security and Exchange Commission (SEC) or foreign equivalent filing, ownership disclosure can be met by providing links to the website(s) containing the last annual filing(s) with the federal Securities and Exchange Commission (or foreign equivalent) that contain the name and address of each person holding a 10% or greater beneficial interest in the publicly traded parent entity, along with the relevant page numbers of the filing(s) that contain the information on each such person. **Attach additional sheets if more space is needed.**

Website (URL) containing the last annual SEC (or foreign equivalent) filing	Page #'s

Please list the names and addresses of each stockholder, partner or member owning a 10 percent or greater interest in any corresponding corporation, partnership and/or limited liability company (LLC) listed in Part II **other than for any publicly traded parent entities referenced above.** The disclosure shall be continued until names and addresses of every noncorporate stockholder, and individual partner, and member exceeding the 10 percent ownership criteria established pursuant to N.J.S.A. 52:25-24.2 has been listed. **Attach additional sheets if more space is needed.**

Stockholder/Partner/Member and Corresponding Entity Listed in Part II	Home Address (for Individuals) or Business Address

Part IV Certification

I, being duly sworn upon my oath, hereby represent that the foregoing information and any attachments thereto to the best of my knowledge are true and complete. I acknowledge: that I am authorized to execute this certification on behalf of the bidder/proposer; that the **<name of contracting unit>** is relying on the information contained herein and that I am under a continuing obligation from the date of this certification through the completion of any contracts with **<type of contracting unit>** to notify the **<type of contracting unit>** in writing of any changes to the information contained herein; that I am aware that it is a criminal offense to make a false statement or misrepresentation in this certification, and if I do so, I am subject to criminal prosecution under the law and that it will constitute a material breach of my agreement(s) with the, permitting the **<type of contracting unit>** to declare any contract(s) resulting from this certification void and unenforceable.

Full Name (Print):	Theodore Sims	Title:	Managing Partner
Signature:		Date:	February 8, 2021

G. Indicate if supplier holds any of the below certifications in any classified areas and include proof of such certification in the response:

a. Minority Women Business Enterprise

Yes No

If yes, list certifying agency: City of Houston; Texas Comptrollers Office

b. Small Business Enterprise (SBE) or Disadvantaged Business Enterprise (DBE)

Yes No

If yes, list certifying agency: City of Houston; Texas Comptrollers Office

c. Historically Underutilized Business (HUB)

Yes No

If yes, list certifying agency: Texas Comptrollers Office

d. Historically Underutilized Business Zone Enterprise (HUBZone)

Yes No

If yes, list certifying agency: _____

e. Other recognized diversity certificate holder

Yes No

If yes, list certifying agency: Disadvantaged Business Enterprise

H. List any relationships with subcontractors or affiliates intended to be used when providing services and identify if subcontractors meet minority-owned standards. If any, list which certifications subcontractors hold and certifying agency.

I. Describe how supplier differentiates itself from its competitors.

J. Describe any present or past litigation, bankruptcy or reorganization involving supplier.

K. Felony Conviction Notice: Indicate if the supplier

a. is a publicly held corporation and this reporting requirement is not applicable;

b. is not owned or operated by anyone who has been convicted of a felony; or

c. is owned or operated by and individual(s) who has been convicted of a felony and provide the names and convictions.

L. Describe any debarment or suspension actions taken against supplier

3.2 Distribution, Logistics

A. Each offeror awarded an item under this solicitation may offer their complete product and service offering/a balance of line. Describe the full line of products and services offered by supplier.

- c) Offeror is not currently delinquent in the payment of any franchise taxes.
 - d) The individual signing the submittal is an authorized agent for the Offeror and has the authority to bind the Offeror to the Contract.
10. Waiver: By submitting a proposal, Offeror expressly agrees to waive any claim it has or may have against Region 4 ESC, its directors, officers, its trustees, or agents arising out of or in connection with (1) the administration, evaluation, recommendation of any proposal; (2) any requirements under the solicitation, proposal package, or related documents; (3) the rejection of any proposal or any part of any proposal; and/or (4) the award of a Contract, if any.

Region 4 ESC shall not be responsible or liable for any costs incurred by Offerors or the successful Offeror in connection with responding to the RFP, preparing for oral presentations, preparing and submitting a proposal, entering or negotiating the terms of a Contract, or any other expenses incurred by an Offeror. The Offeror is wholly responsible for any such costs and expenses and shall not be reimbursed in any manner by Region 4 ESC.

11. Conditions of Submitting Proposal: Submission of a proposal confers no right on an Offeror to an award or Contract. Region 4 ESC, in its sole discretion and for any reason or no reason, reserves the rights to reject any or all proposals, accept only a part of any proposal, accept the proposal deemed most advantageous to Region 4 ESC, and waive any technicalities. The issuance of this RFP does not obligate Region 4 ESC to make an award or negotiate or execute a Contract. Prior to submission due date and time, Region 4 ESC reserves the right to amend the terms and provisions of the RFP, extend the deadline for submission of proposals, or withdraw the RFP entirely for any reason solely at Region 4 ESC's discretion. A proposal may be rejected if it fails to meet any requirement of this RFP.
12. Mailing of Proposals: All proposals submitted in response to the solicitation must be clearly identified as listed below with the solicitation number, title, name and address of the company responding. All packages must be clearly identified as listed below, sealed and delivered to the Region 4 ESC office no later than the submittal deadline assigned for this solicitation.

From Theodore Sims LEED AP
Company TSG Industries
Address 7040 Rook Blvd.
City, State, Zip Houston, Texas 77087
Solicitation Name and Number 2020_12_03 Due Date and Time February 9, 2021

13. Amendment of Proposal: A proposal may be amended prior to the time of opening by submitting a sealed letter to the location indicated on the front page of this solicitation.
14. Withdrawal of Proposals: Withdrawal of proposals prior to the opening date will be permitted by a written letter or electronic mail from the Offeror. Telephonic or oral withdrawals shall not be considered. After the opening date consideration may be given in cases where Offeror advises that it made a clerical error that is substantially lower than it intended. In such case, Offeror must provide written notice of their desire to withdraw, along with supporting documents, within 3 business days of receiving the acceptance letter or of being requested by Region 4 ESC for clarification of the proposal, whichever is later. Any Contract entered into

RECEIPT OF ADDENDUM NO. 1 ACKNOWLEDGEMENT

Offeror shall acknowledge this addendum by signing below and include in their proposal response.

Company Name TSG Industries

Contact Person Theodore Sims

Signature 

Date February 8, 2021

Crystal Wallace
Region 4 Education Service Center
Business Operations Specialist

QUESTIONS AND ANSWERS

1. Question: Could you tell us where this project is located? City/State?

Answer: Region 4 Education Service Center) is located in Houston, Texas but this is to be a national contract serving multiple Participating Public Agencies across the country.

2. Question: What city is this project in?

Answer: See Answer to Question #1.

3. Question: Do you anticipate extending the bid due date?

Answer: See item #1 under Changes to the RFP in this Addendum.

4. Question: What additional details are you willing to provide, if any, beyond what is stated in bid documents concerning how you will identify the winning bid?

Answer: Any pertinent information is included in the RFP.

5. Question: Was this bid posted to the nationwide free bid notification website at [//www.mygovwatch.com/free](http://www.mygovwatch.com/free)?

Answer: Not by Region 4 Education Service Center.

6. Question: Other than your own website, where was this bid posted?

Answer: The only other known locations where this solicitation was advertised is: The OMNIA Partners site through a link that directs viewers to Region 4 Education Service Center's site (<https://www.omniapartners.com/publicsector/solicitations>) and in various newspapers across the country.

However, there are other third-party sites that often pick up and post public solicitations but which of those sites might have posted this solicitation is unknown.

7. Question: Please let us know whether you have received this email, and when and how answers will be provided.

Answer: Any questions received in writing before the deadline are posted in a questions and answers document(s) and posted publicly to ensure all interested parties have the same information.

RECEIPT OF ADDENDUM NO. 2 ACKNOWLEDGEMENT

Offeror shall acknowledge this addendum by signing below and include in their proposal response.

Company Name TSG Industries

Contact Person Theodore Sims

Signature  _____

Date February 8, 2021

Crystal Wallace
Region 4 Education Service Center
Business Operations Specialist

RECEIPT OF ADDENDUM NO. 3 ACKNOWLEDGEMENT

Offeror shall acknowledge this addendum by signing below and include in their proposal response.

Company Name TSG Industries

Contact Person Theodore Sims

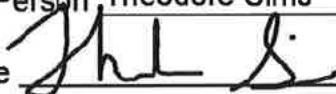
Signature 

Date February 8, 2021

Crystal Wallace
Region 4 Education Service Center
Business Operations Specialist

RECEIPT OF ADDENDUM NO. 4 ACKNOWLEDGEMENT

Offeror shall acknowledge this addendum by signing below and include in their proposal response.

Company Name TSG INDUSTRIES

Contact Person THEODORE SIMS

Signature 

Date 2-19-2021

Crystal Wallace
Region 4 Education Service Center
Business Operations Specialist

CERTIFICATE OF INTERESTED PARTIES

FORM 1295

1 of 1

Complete Nos. 1 - 4 and 6 if there are interested parties.
 Complete Nos. 1, 2, 3, 5, and 6 if there are no interested parties.

OFFICE USE ONLY CERTIFICATION OF FILING

Certificate Number:
 2021-714773

Date Filed:
 02/08/2021

Date Acknowledged:

1 Name of business entity filing form, and the city, state and country of the business entity's place of business.

TSG Industries
 Houston, TX United States

2 Name of governmental entity or state agency that is a party to the contract for which the form is being filed.

Region 4 Education Service Center

3 Provide the identification number used by the governmental entity or state agency to track or identify the contract, and provide a description of the services, goods, or other property to be provided under the contract.

21-05
 Modular Building Systems

4	Name of Interested Party	City, State, Country (place of business)	Nature of interest (check applicable)	
			Controlling	Intermediary

5 Check only if there is NO Interested Party.

6 UNSWORN DECLARATION

My name is THEODORE SIMS, and my date of birth is 03/03/1981.

My address is 7040 ROOK BLVD, HOUSTON, TX, 77087, U.S.
(street) (city) (state) (zip code) (country)

I declare under penalty of perjury that the foregoing is true and correct.

Executed in HARRIS County, State of TEXAS, on the 13 day of FEBRUARY 2021.
(month) (year)

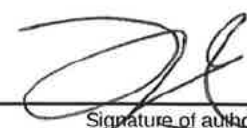

 Signature of authorized agent of contracting business entity (Declarant)

ACKNOWLEDGMENT AND ACCEPTANCE
OF REGION 4 ESC's OPEN RECORDS POLICY

OPEN RECORDS POLICY

All proposals, information and documents submitted are subject to the Public Information Act requirements governed by the State of Texas once a Contract(s) is executed. If an Offeror believes its response, or parts of its response, may be exempted from disclosure, the Offeror must specify page-by-page and line-by-line the parts of the response, which it believes, are exempt and include detailed reasons to substantiate the exemption. Price is not confidential and will not be withheld. Any unmarked information will be considered public information and released, if requested under the Public Information Act.

The determination of whether information is confidential and not subject to disclosure is the duty of the Office of Attorney General (OAG). Region 4 ESC must provide the OAG sufficient information to render an opinion and therefore, vague and general claims to confidentiality by the Offeror are not acceptable. Region 4 ESC must comply with the opinions of the OAG. Region 4 ESC assumes no responsibility for asserting legal arguments on behalf of any Offeror. Offeror is advised to consult with their legal counsel concerning disclosure issues resulting from this procurement process and to take precautions to safeguard trade secrets and other proprietary information.

Signature below certifies complete acceptance of Region 4 ESC's Open Records Policy, except as noted below (additional pages may be attached, if necessary).

Check one of the following responses to the Acknowledgment and Acceptance of Region 4 ESC's Open Records Policy below:

- We acknowledge Region 4 ESC's Open Records Policy and declare that no information submitted with this proposal, or any part of our proposal, is exempt from disclosure under the Public Information Act.
- We declare the following information to be a trade secret or proprietary and exempt from disclosure under the Public Information Act.

(Note: Offeror must specify page-by-page and line-by-line the parts of the response, which it believes, are exempt. In addition, Offeror must include detailed reasons to substantiate the exemption(s). Price is not confidential and will not be withheld. All information believed to be a trade secret or proprietary must be listed. It is further understood that failure to identify such information, in strict accordance with the instructions, will result in that information being considered public information and released, if requested under the Public Information Act.)

February 8, 2021

Date



Managing Partner
Authorized Signature & Title

ANTITRUST CERTIFICATION STATEMENTS
(Tex. Government Code § 2155.005)
Attorney General Form

I affirm under penalty of perjury of the laws of the State of Texas that:

1. I am duly authorized to execute this Contract on my own behalf or on behalf of the company, corporation, firm, partnership or individual (Company) listed below;
2. In connection with this proposal, neither I nor any representative of the Company has violated any provision of the Texas Free Enterprise and Antitrust Act, Tex. Bus. & Comm. Code Chapter 15;
3. In connection with this proposal, neither I nor any representative of the Company has violated any federal antitrust law; and
4. Neither I nor any representative of the Company has directly or indirectly communicated any of the contents of this proposal to a competitor of the Company or any other company, corporation, firm, partnership or individual engaged in the same line of business as the Company.

Company

TSG Industries

Contact



Signature

Theodore Sims

Printed Name

Principal Manager

Position with Company

Address

7040 Rook Blvd.

Houston, Texas 77087

**Official
Authorizing
Proposal**



Signature

Theodore Sims

Printed Name

Managing Partner

Position with Company

Phone

1-888-586-2703

Fax

ACKNOWLEDGMENT AND ACCEPTANCE
OF REGION 4 ESC's OPEN RECORDS POLICY

OPEN RECORDS POLICY

All proposals, information and documents submitted are subject to the Public Information Act requirements governed by the State of Texas once a Contract(s) is executed. If an Offeror believes its response, or parts of its response, may be exempted from disclosure, the Offeror must specify page-by-page and line-by-line the parts of the response, which it believes, are exempt and include detailed reasons to substantiate the exemption. Price is not confidential and will not be withheld. Any unmarked information will be considered public information and released, if requested under the Public Information Act.

The determination of whether information is confidential and not subject to disclosure is the duty of the Office of Attorney General (OAG). Region 4 ESC must provide the OAG sufficient information to render an opinion and therefore, vague and general claims to confidentiality by the Offeror are not acceptable. Region 4 ESC must comply with the opinions of the OAG. Region 4 ESC assumes no responsibility for asserting legal arguments on behalf of any Offeror. Offeror is advised to consult with their legal counsel concerning disclosure issues resulting from this procurement process and to take precautions to safeguard trade secrets and other proprietary information.

Signature below certifies complete acceptance of Region 4 ESC's Open Records Policy, except as noted below (additional pages may be attached, if necessary).

Check one of the following responses to the Acknowledgment and Acceptance of Region 4 ESC's Open Records Policy below:

- We acknowledge Region 4 ESC's Open Records Policy and declare that no information submitted with this proposal, or any part of our proposal, is exempt from disclosure under the Public Information Act.
- We declare the following information to be a trade secret or proprietary and exempt from disclosure under the Public Information Act.

(Note: Offeror must specify page-by-page and line-by-line the parts of the response, which it believes, are exempt. In addition, Offeror must include detailed reasons to substantiate the exemption(s). Price is not confidential and will not be withheld. All information believed to be a trade secret or proprietary must be listed. It is further understood that failure to identify such information, in strict accordance with the instructions, will result in that information being considered public information and released, if requested under the Public Information Act.)

February 8, 2021

Date



Managing Partner
Authorized Signature & Title

Texas Government Code 2270 Verification Form

House Bill 89 (85R Legislative Session), which adds Chapter 2270 to the Texas Government Code, provides that a governmental entity may not enter into a contract with a company without verification that the contracting vendor does not and will not boycott Israel during the term of the contract.

Furthermore, Senate Bill 252 (85R Legislative Session), which amends Chapter 2252 of the Texas Government Code to add Subchapter F, prohibits contracting with a company engaged in business with Iran, Sudan or a foreign terrorist organization identified on a list prepared by the Texas Comptroller.

I, Theodore Sims, as an authorized representative of TSG Industries, a contractor engaged by Insert Name of Company

Region 4 Education Service Center, 7145 West Tidwell Road, Houston, TX 77092, verify by this writing that the above-named company affirms that it (1) does not boycott Israel; and (2) will not boycott Israel during the term of this contract, or any contract with the above-named Texas governmental entity in the future.

Also, our company is not listed on and we do not do business with companies that are on the Texas Comptroller of Public Accounts list of Designated Foreign Terrorists Organizations found at <https://comptroller.texas.gov/purchasing/docs/foreign-terrorist.pdf>.

I further affirm that if our company's position on this issue is reversed and this affirmation is no longer valid, that the above-named Texas governmental entity will be notified in writing within one (1) business day and we understand that our company's failure to affirm and comply with the requirements of Texas Government Code 2270 et seq. shall be grounds for immediate contract termination without penalty to the above-named Texas governmental entity.

I swear and affirm that the above is true and correct.



Signature of Named Authorized Company Representative

February 8, 2021

Date

STOCKHOLDER DISCLOSURE CERTIFICATION

Name of Business:

I certify that the list below contains the names and home addresses of all stockholders holding 10% or more of the issued and outstanding stock of the undersigned.

OR

I certify that no one stockholder owns 10% or more of the issued and outstanding stock of the undersigned.

Check the box that represents the type of business organization:

Partnership Corporation Sole Proprietorship

Limited Partnership Limited Liability Corporation Limited Liability Partnership

Subchapter S Corporation

Sign and notarize the form below, and, if necessary, complete the stockholder list below.

Stockholders:

Name: Theodore Sims	Name:
Home Address: 7040 Rook Blvd. Houston, Texas 77087	Home Address:
Name:	Name:
Home Address:	Home Address:
Name:	Name:
Home Address:	Home Address:

Subscribed and sworn before me this 13th day of February 2021

(Notary Public) Tiffany Poole

My Commission expires: 10/1/2024

[Signature]
(Affiant)

THEODORE SIMS, OWNER
(Print name & title of affiant)

(Corporate Seal)

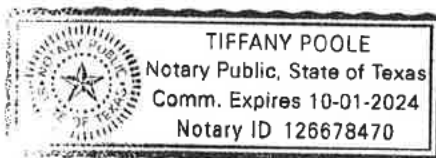

OFFER AND CONTRACT SIGNATURE FORM

The undersigned hereby offers and, if awarded, agrees to furnish goods and/or services in strict compliance with the terms, specifications and conditions at the prices proposed within response unless noted in writing.

Company Name TSG Industries
Address 7040 Rook Blvd.
City/State/Zip Houston, Texas 77087
Telephone No. 1-888-586-2703
Email Address tsims@tsg-industries.com
Printed Name Theodore Sims
Title Project Executive
Authorized signature 

Accepted by Region 4 ESC:

Contract No. _____

Initial Contract Term _____ to _____

Region 4 ESC Authorized Board Member

Date

Print Name

Region 4 ESC Authorized Board Member

Date

Print Name

